

COLLEGE OF CONTINUING EDUCATION

UNIVERSITY OF MINNESOTA

# BEST VALUE PROCUREMENT: LESSONS LEARNED

A Review of Best Practices in Minnesota: 2008-2009

September 17, 2009

*“The best qualified contractor for the price considered most fair.”*

**A. Peter Hilger, AIA**

Faculty, Construction Management  
University of Minnesota  
College of Continuing Education  
Applied and Professional Studies  
Bachelor of Applied Science

**Edited by Ann Houske Jacklitch**

and the students in CMgt 4550, Topics in Construction Management  
University of Minnesota  
Fall Semester 2008

**Abstract**

---

On the heels of the I-35W Bridge collapse in Minneapolis in August 2007, a contract for the bridge's rapid replacement using best value procurement (BVP) caught the public attention. Earlier that same year, best value legislation had enabled state and local government units and related public agencies to use best value to procure projects. Though the practice has been in use only since 2001, and is not widely understood, the University of Minnesota Construction Management faculty and students embarked on a research program to evaluate its current state. They used ten standard procurement parameters, the practice's statutory foundation, and a summary of best practices that can be used by state and local government units in formulating their future procurement procedures. The research examined specific projects and practices of the Minnesota Department of Administration, the Minnesota Department of Transportation, the University of Minnesota Capital Planning and Project Management Group, the Cities of Roseville and Eagan, the SoWashCo School District, Regions Hospital, the Minnesota Ballpark Authority, and several private sector owner's representatives.

## TABLE OF CONTENTS

---

Introduction	2
So What Is Best Value?	3
Evolution of Best Value as a Procurement Method	4
Why the Study?	7
Research Methodology: the Ten Parameters	8
Research Methodology: the Agencies Examined	9
The Legal Foundation for Best Value	11
The Ten Parameters	14
Solicitation	14
Qualification	15
Qualifying: of Formulas and Filters	16
Transparency and Neutrality	20
Delivery Method	26
Risk	27
Schedule	29
Time/Cost Relationship	30
Change Management	31
Scope Management	34
Separation of Responsible Parties	35
The Contractor's Perspective	38
Public Perception of Best Value	41
Training	43
Lessons Learned: Six Best Practices	44
Acknowledgements	46
Appendixes	
1 - Legal	48
2 - Minnesota Department of Administration	52
3 - Minnesota Department of Transportation	60
4 - University of Minnesota	67
5 - City and County Agencies—General	77
6 - City of Roseville Ice Rink	79
7 - City of Eagan	89
8 - Regions Hospital Expansion	95
9 - Ballpark Authority / Twins Stadium	100
10 - South Washington County School District	107
11 - Private Sector, Public Perceptions	113
12 - Training	118

## **INTRODUCTION**

Best Value Procurement (BVP) is a relatively new procurement process for public agencies, a process of acquiring construction-related services or commodities that mirrors the long-used practices of design-build and negotiated agreements in the private sector. In theory, it is a process by which public and quasi-public agencies can hire a designer and/or contractor with the best experience, the best project proposal, and a bid that reflects these values. BVP supports the view that the lowest responsive, responsible bidder is not always the best qualified to assume the risks of a particular project, and that possible service deficiencies in that bidder can cause excessive change orders and litigation for a public agency, with ultimate impact on the taxpayer. Minnesota's public agencies use various forms of procurement, which we will compare, contrast, and evaluate, each on its own merits.



Left: The Collapse of the St. Anthony Bridge, August 1, 2007 (Source: MnDOT Website)

Below: The replacement bridge nearing completion, late summer 2008 (source: MnDOT Website)

## SO WHAT IS “BEST VALUE”?

Research reveals that best value procurement is widely misunderstood, certainly from the public perspective, but equally by the construction industry. The dictionary defines the terms as follows:

**best** (běst) *adj.* Superlative of good. 1) Surpassing all others in excellence, achievement or quality; most excellent. . .

**value** (văl' yōō) *n.* 1. An amount, as of goods, services or money considered a fair and suitable equivalent for something else; a fair price or return.<sup>1</sup>

Best value procurement is not a delivery method, because it has proven to be effective with both design-bid-build and design-build projects. Rather, best value procurement is a means of sourcing a supplier of a project. Though the use of the practice varies among the agencies surveyed, from “very actively used” to “not at all,” the reason for using best value is fairly consistent: *to match the best qualified contractor to the project, thereby reducing the owner’s risk and increasing the value received.* In order to achieve this result, the methodology an agency uses to qualify a contractor for a specific project is critical. The 2007 best value legislation that will be discussed later essentially requires only that procurement using best value must consider price and performance criteria.<sup>2</sup> A common definition can be suggested as follows:

A method of procurement that matches project requirements, as defined by the construction documents, with a contractor that is best able to complete the project, factoring in contractor qualifications, experience, technical competency, construction planning, and cost, using a formulaic scoring methodology.

Or more simply:

The best qualified contractor for the price considered most fair.

---

<sup>1</sup> *The American Heritage Dictionary of the English Language*, Fourth Ed., Houghton Mifflin Co., 2000.

<sup>2</sup> Dean B. Thomson, Mark Becker, and Jeffrey Wieland, “A Critique of Best Value Contracting in Minnesota,” *William Mitchell Law Review*, Vol. 34, No. 1, 2007, pg. 47. [The reader is encouraged to consult this excellent resource citing the history of best value in Minnesota.]



## **EVOLUTION OF BEST VALUE AS A PROCUREMENT METHOD**

The public sector has always wished for the flexibility that the private sector enjoys in selecting who it wants to deliver a project. The private sector does not have to abide by bidding rules and can contract with whoever it feels will best do the job. Theoretically, one would then assume that the private sector has been able to properly qualify and manage its risk; however, this typically has proven not to be the case, because the private sector has demonstrated the ability to become ensnared in construction disputes. The private sector has had difficulty matching the appropriate qualifications of the contractor with the project, and has instead based its selections, whether right or wrong, on relationships.

Further, the use of design-build as a bona fide private sector delivery method has in some respects been the envy of the public sector. The intent of design-build is to match the expertise of a team, typically consisting of an architect and/or engineer with a contractor, in a single-source contract to both design and build the project, thereby reducing the owner's risk of the change orders and cost increases that have traditionally been the bane of design-bid-build projects. While no delivery method is perfect, each has merits that fit the requirements of a specific project. It is the notion of transferring the owner's risk to the contractor and reducing the seemingly endemic construction cost overruns resulting from design-build that has gained the attention of the public sector.

The traditional method of lowest responsive, responsible bidder has long been the only way for public procurement to occur. The rules have generally been interpreted to mean that a contractor, even with little direct project experience, is able to bid on a project if the contractor meets the bidding criteria and posts a bond.<sup>1</sup> This means that the contractor can potentially fail to adequately deliver the project. This has led to frustration in the public sector, which has been powerless to do anything about it. So while a contractor may technically meet all the performance standards of the project, the project may have come in at a much higher price due to change orders and/or missed deadlines. Therefore, the best value may not have been achieved.

This is not to suggest that the lowest responsive, responsible bidding process does not have its successes. When the contractor is properly qualified, and when the scope is completely and clearly defined in the documents, there are many more success stories than failures. However, it is these failures that seem to garner the attention of the public, and they have put more pressure on public agencies to improve their procurement process in an effort to reduce time delays and added costs.

A 2001 study of design-build practices at the state level concluded that the following objectives, in order of priority, support the use of design-build (and presumably a best value process) by the state transportation agencies:<sup>2</sup>

---

<sup>1</sup> Editor's note: The surety company "qualifies" the contractor by its willingness to extend or not extend bonding credit.

<sup>2</sup> Paul Huston, *Design-Build Measures of Effectiveness for State Transportation Agency Highway Projects*, December 2001 (as cited in Ward, *ROC 52 Case Study*).

1. Shorten duration.
2. Establish schedule.
3. Reduce claims.
4. Support constructability.
5. Establish cost.
6. Support a large/complex project.
7. Reduce cost.

These objectives resulted in the first law, the 2001 design-build law, which enabled the Minnesota Department of Transportation (MnDOT) to develop a fair and balanced procurement process using a design-build delivery method on a limited number of projects.

Best value in Minnesota traces its roots to the late 1990s with the planning of the Hiawatha Light Rail Corridor project that, because of its complexity and multi-agency participation, was legislatively prescribed to be performed using a best value procurement process. The project was managed by the Hiawatha Project Office (HPO), a joint effort of MnDOT and the Metropolitan Council. A request for qualification was issued in October 1999 to solicit design-build teams technically and financially best able to complete this complex rail project. Five teams were selected to receive an RFP.

The enabling legislation directed MnDOT to procure using a design-build best value fixed maximum price based on the limited budget available for the project. The request for proposal was unusual in that it fixed the maximum cost of the project and it evaluated proposals based upon the amount of scope each contractor could fulfill for the fixed maximum price, including additive and deductive alternatives. The Minnesota Transit Constructors Consortium, consisting of Granite Construction, C.S. McCrossan, Parsons, and Edwards & Kelcey for the design, won the project. The tunnel and vehicles were done on a traditional design-bid-build basis, and the extension to the Mall of America was a change to the original design-build scope. The Metropolitan Council assigned MnDOT the task of contractually managing design-build efforts since MnDOT had more experience as construction managers of infrastructure projects. The Hiawatha process also introduced “alternative technical concepts” (ATCs) wherein the design-build teams could suggest alternative design or construction procedures using an exclusive “blind” review and approval process overseen by MnDOT. Similar ATC processes have been used by MnDOT on subsequent design-build projects.<sup>1</sup> Indeed, the unique procurement aspect of the Hiawatha Light Rail project was not the development of price, but the determination of best value that maximized the scope delivered for that maximum price.

MnDOT's true incentive to develop a better procurement methodology was born out of funding necessity rather than the desire to “try something new.” Using the Hiawatha Corridor experience as a backdrop, the \$232 million MnROC 52 project that significantly expanded Highway 52 in Rochester was initially contemplated as requiring 15 separate projects and 11 years to complete using traditional design-bid-build means. However, the federal funding for the project was available in its entirety and required the project to be delivered in a substantially shorter than usual time period to qualify for the funding, resulting in the largest one-time project letting in the state at that time. Enabling legislation was quickly passed to allow MnDOT to take advantage of the funding and thoroughly develop the methodology that was already in use in many other states. The MnROC 52 project was the first MnDOT design-build project and was completed in three years (by November 2005) even though the contractors were given five years to complete

---

<sup>1</sup> Relayed by Mr. Robert Sands, PE, member of the design-build management team for the project, March 18, 2009.

the project.<sup>1</sup> With this thorough grounding in process, MnDOT was able to complete five additional projects prior to awarding the I-35W Bridge replacement and having to quickly develop the process for its delivery.

The success at the state level was noted and followed by other agencies, including the University of Minnesota with its own need for improving its procurement process. The University had been struggling with numerous change orders, which affected both cost and schedule and resulted in disgruntled customers. The University embraced the opportunity to secure best value by modeling its program after Arizona State University's PIPS (Performance Information Procurement System). Arizona State University's concept of minimizing risk, increasing performance, and increasing efficiency with its model for a full-information environment offered through their PIPS process has enabled CPPM to dramatically reduce change orders initiated by contractors by addressing risk up front and effectively transferring risk from the University to the contractor. This transfer of risk has meant reduced project costs (most likely the result of reduced change orders), a reduction in schedule extensions, and most importantly, a dramatic increase in customer satisfaction for the University.<sup>2</sup> And while many contractors have adopted the process, with its heavy dependence on writing and paperwork, it has been with some trepidation and concern, according to casual comments from a few participating contractors contacted. The perception of best value from the contractor's point of view was not a matter for this research. That question is left instead to a future, broader study, once best value has a greater foothold within the state.

---

<sup>1</sup> Terry Ward, MnDOT project manager, *ROC 52 Case Study*, Infrastructure and Systems Engineering Program, University of Minnesota, 2005.

<sup>2</sup> Nacole Kaai and John Savicky, *Best Value Procurement*, University of Minnesota, AE PIPS Outreach, March 2008.

## **WHY THE STUDY?**

In the early evening of August 1, 2007, the collapse of the Interstate I-35W St. Anthony Bridge in Minneapolis, Minnesota, sent a warning to the nation and the world that our crumbling infrastructure systems require more attention, from both engineering and investment perspectives. On August 23, requests for proposals to invited contractors were released, with technical proposals received September 14 and cost proposals received September 18. By September 19, a mere 49 days after the collapse, the State of Minnesota, using “emergency powers” and working in cooperation with several federal agencies, awarded the bridge replacement project to the joint venture Flatiron/Manson. It used a process that ultimately awarded a \$234 million contract to the proposer with the highest technical score, highest cost, and, at the time of award, the longest projected duration. As one might expect, the process known as “best value procurement,” which was not widely understood by the public, was questioned in the media. It seemed somewhat counterintuitive: awarding the job to the highest bidder with the longest schedule, a practice that is extremely rare, in fact almost unheard of, in the public bidding arena.

It was the events following the collapse and award of the bridge replacement that stimulated the need for a broader investigation into the process of best value procurement and its origins and applications. One of these investigations was a Special Topics research study within the University of Minnesota’s Construction Management program, the purpose of which was to

- Examine the legal foundation for BVP.
- Examine its application among public and quasi-public agencies.
- Develop a slate of best practices that could be used by any agency in developing its own best value procurement process.
- Determine what types of projects might best fit the BVP application.

In the subsequent investigation, we found the agencies approached very willing to participate in the study and having an avid interest in the outcomes. The best value process is still being “learned,” and there is a great deal of curiosity how other agencies may also be achieving their goals, but with more efficiency and less risk. We have discovered that practices vary greatly depending on the enabling legislation, the nature of the delivery method, and whether or not the agency has participated in a training program.

## **RESEARCH METHODOLOGY: THE TEN PARAMETERS**

The research focused on ten essential parameters that represent the “standard” of conventional procurement and the areas around which best value would be examined to determine whether these parameters were affected in any way by the use of best value. The parameters are as follows:

Solicitation	The means of obtaining contractors to bid on a project
Qualification	The means for certifying contractors to bid on a project
Transparency/Neutrality	Maintenance of an open, fair, and unbiased approach prior to the award of a contract
Delivery Methods	Impact of design-bid-build, design-build, and construction manager at risk on the use of best value procurement
Risk	Project risk management for the owner, comparing best value procurement to the traditional lowest responsive, responsible bidder process
Schedule	Effect of best value on the schedule
Time/Cost Relationship	Impact of best value on project delivery—cost and speed
Change Management	Impact of best value on the change order process
Scope Management:	Effect of best value on the owner’s ability to manage program requirements
Separation of Responsible Parties	Impact of best value on the separation of architect, owner, and contractor

Each of these parameters is examined in greater detail in the following pages, and the best practices of best value procurement are identified. First, it is important to lay the groundwork for how BVP can be implemented, and why, and the legal basis for its use by public agencies.

## **RESEARCH METHODOLOGY: THE AGENCIES EXAMINED**

Our methodology employed research and interviews with procurement officials involved in public agencies, quasi-public agencies, and the private sector. The public agencies examined as part of our research included the Minnesota Department of Administration, the Minnesota Department of Transportation (MnDOT), the University of Minnesota Capital Planning and Project Management Group (University CPPM), the Cities of Roseville and Eagan, plus other city/county agencies, along with the South Washington County School District (SoWashCo). These agencies were researched because they chose to actively pursue and experiment with a form of best value procurement that would deliver the best value for their agency, as an alternative to using the traditional lowest responsive, responsible bidder standard.

Minn. Dept of Administration	Renovation of the Department of Transportation Building: \$18 million, best value procurement
MnDOT	I-35W Bridge replacement with a joint venture of Flatiron/Manson, a \$234 million design-build, best value procurement
University of Minnesota	Capital Planning and Project Management Group (CPPM), use of Best Value for a variety of remodeling projects
City of Roseville Parks Dept.	Replacement of the Roseville Ice Arena mechanical systems, a \$1 million project using best value procurement
City of Eagan Engineering Dept.	Discussion of various street improvement projects using best value procurement
SoWashCo School District	Examination of new multi-phased \$107-million high school in Woodbury, using a construction manager, agency-based consultant managing a lowest responsive, responsible bid approach for the South Washington County School District

To obtain a more complete perspective on best value procurement, two quasi-public agencies were also considered. Quasi-public agencies, as we are defining them, are private organizations that may have paired with a public agency, received funding from a public source, or, by virtue of their public appeal, have either sought or were required to pursue a more open, transparent procurement system. These include the following:

Regions Hospital Expansion	A major \$179 million expansion of the Ramsey County hospital, owned and operated by HealthPartners and administered by a construction manager using a hybrid design-build approach with a cost-plus guaranteed maximum price delivery. Best value concepts were used in the selection of the architect and contractor.
Ballpark Authority	Construction of the Minnesota Twins stadium involves \$350 million of Hennepin County taxpayer investment in the \$520 million dollar project, using a hybrid best value procurement process administered by a construction manager representing each party to the process.

Finally, we interviewed several owner's representatives dealing with private procurement to determine the private sector's impact on best value procurement in the public sector, and whether, in turn, the use of best value procurement by the public sector has influenced the private sector. These include Wellington Management, a St. Paul-based private development firm and Sterns Associates, a St. Paul-based firm specializing in private sector and non-profit owner's representation service.

Only the University of Minnesota and MnDOT have a relatively long history using one form or another of best value procurement; the others investigated are currently working on their first project, or not at all. This makes it more difficult to find commonalities among the agencies, but by using the ten parameters as a measuring stick, the consistent themes and practices can be identified.

### **Research Methodology: Research Teams**

To assess current practices, student teams examined the use of best value procurement within their assigned agencies by looking at how the agencies first considered using best value or similar concepts; how best value impacts the agency's internal project management structure (which can be significant for agencies that have not used it before); and how the contractor is held responsible. Using interview techniques, students asked why best value is either appropriate or inappropriate for the agency. Additionally, the criteria (filters) or steps the agencies used in choosing best value, what was perceived as the strengths and weaknesses of best value, and what impact best value has had on the historical change order rate for projects relative to the gross value of construction were examined. Finally, the time when best value was used on a project and the process or criteria used to determine its use, as opposed to more traditional procurement methods, were researched.

Please see the appendixes for the summary of research on each agency examined.



Completed East Ridge High School, South Washington County School District

(Photo: The author, September 2009)

## **THE LEGAL FOUNDATION FOR BEST VALUE**

Time and again, the Minnesota Supreme Court has expressed concern over the system for awarding contracts and the opportunities it has afforded public officials for abuse, fraud, and favoritism. As a result, the competitive bidding process became so narrowly defined that public agencies had little or no opportunity to make subjective decisions. Prior to the best value legislation, lowest responsive, responsible bidder was the predominant acquisition process.<sup>1</sup>

In 2001, MnDOT was the first public agency allowed by legislation to use design-build to solicit and award a contract for a project on the basis of a best value selection process.<sup>2</sup>

In 2005, after nearly two years of joint research by the affected public agencies and contractor associations, legislation was passed giving the Minnesota Department of Administration and the Minnesota State Colleges and Universities (MnSCU) authority to use construction manager at risk (CMAR), job order contracting, and design-build contracting; and the University of Minnesota was given the authority to use design-build (D-B) contracting and CMAR.<sup>3</sup>

In May of 2006, the state legislature approved the use of best value procurement for the Minnesota Twins ballpark using a combination of public funding to be administered by the Ballpark Authority (which was created to protect the use of the taxpayer's money) and funding provided by the Twins along with their agreement to take on the responsibility for any cost overruns. The legislation granted the Twins the authority to select their own construction manager. The Twins were also required to sign a 30-year lease, ensuring long-term use of the facility for its original purpose as a major league baseball stadium.<sup>4</sup>

The 2007 best value legislation mandated that any agency for which competitive bids or proposals are required may use best value procurement or the traditional lowest responsive, responsible bidder. The legislation mandates that best value procurement must consider price and performance criteria<sup>5</sup> such as, but not limited to

- Quality, timeliness, and level of customer satisfaction on previous projects
- Past capability to stay on budget and ability to minimize change orders
- Ability to prepare appropriate documents
- Technical capabilities
- Qualifications of individual personnel
- Ability to assess and minimize risk

The 2007 legislation was implemented in phases, with the first two years permitting state agencies, counties, cities, and school districts with the highest 25% enrollment to use best

---

<sup>1</sup> Thomson, et al., "A Critique of Best Value Contracting in Minnesota," previously cited.

<sup>2</sup> Minnesota Statutes §161.3410; §16C.32; §16C.33.

<sup>3</sup> Thomson et al., previously cited.

<sup>4</sup> Ed Hunter, Dan Mehls, and Dick Strassburg, interview, October 8 & 9, 2008.

<sup>5</sup> Thomson et al., and Minnesota Statutes §16C.02 and §16C.28.



value. Beginning in 2009, school districts with the highest 50% enrollment become eligible, followed in 2010 by all townships, school districts, and political subdivisions. Further, the law limits use of best value on one project, or 20% of projects through 2010.

One of the greatest concerns consistently noted by the agencies examined with the 2007 legislation is the requirement for training for those agencies administering best value procurement (Minn. Stat. §16C.03, subd. 19). The legislation provides few specifics and no funding, other than that agencies may be trained by the Minnesota Department of Administration. There is also concern whether the source of training found at the Arizona State University PBSRG meets the intent of this legislation, or whether less expensive training options would also comply.

An attempt to amend the 2007 best value legislation was made in the 2008 legislative session on the premise of protection for the taxpaying public. However, the omnibus bill to which the amending legislation was attached was threatened with a veto if the language amending best value was not removed.<sup>1</sup>

As of this writing, the current legislative session is considering several changes to the existing MnDOT design-build legislation (Minn. Stat. 161.3410, et al.). The proposed changes include text amendments clarifying, among other things, the definition and determination of a responsive proposal, a revised time factor when used as a selection criterion, and a waiting/review period of seven days prior to the award of a contract.<sup>2</sup> Further, a pilot program is being proposed that would permit MnDOT to establish a design-build pilot contracting program for counties and home rule charter cities in constructing or improving streets and highways on the state-aid system.<sup>3</sup>

## Legal Challenges

As of this writing, there have been no legal challenges to either the University's PIPS process or the 2007 best value legislation. Clearly, with the highest number of projects using best value, the University would presumably be most exposed to legal challenge, but the unique PIPS process it uses is transparent and does not employ (nor is it required to employ) the criteria in the 2007 legislation. Presumably, then, those engaged in the PIPS process have deemed it fair enough to avoid challenge. Both Roseville, by negotiating a value-engineered contract with the low bidder after a best value process, and Eagan, selecting a contractor in a process that questions transparency and neutrality, were not challenged in court but could be deemed to be vulnerable to legal challenge. It appears that as best value is developing and participants are learning the processes involved, all parties involved are acting in good faith and accepting it as a learning process. Other than the University and MnDOT, relatively few projects have actually used a formal best value process, considering the total potential dollar value in infrastructure spending. As the process becomes more common and more refined, litigation challenging an award can be expected, whether or not such a challenge would have merit.<sup>4</sup>

---

<sup>1</sup> Mn. State Representative Debra Hilstrom, interview and presentation, October 8, 2008.

<sup>2</sup> H.F. No. 1815 as introduced – 86<sup>th</sup> legislative session (2009-2010).

<sup>3</sup> H.F. No. 1547 and S.F. No. 1300 as introduced – 86<sup>th</sup> legislative session (2009-2010).

<sup>4</sup> The one recent and notable exception is the contract awarded to Flatiron/Manson by MnDOT for the St. Anthony Falls (I-35W) Bridge design-build project, but readers are advised that the law covering this case is MnDOT's design-build legislation rather than the 2007 best value legislation. (For more discussion of this case, please read the section on Transparency and Neutrality). This case continues in appeal as of this writing, with the bridge complete and fully functional.



Completed Regions Hospital, St. Paul, MN (Photo by the Author, September 2009)

## **THE TEN PARAMETERS**

A few of the agencies researched have a relatively long history of using one form or another of best value, while others investigated are currently working on their first project. This makes it more difficult to look for commonalities within our findings, but by using parameters to consistently compare programs, we can note the constants found.

We have used the Ten Parameters to define specific characteristics of a system or function in our comparison of the various uses of BVP. When evaluating a function over time, the variables continue to vary while the parameters hold constant. The Ten Parameters listed below are addressed for their relevance in this research project.

### **Solicitation**

Definition: *the means of obtaining contractors to bid on a project*

There are very few differences in the manner of soliciting for qualified contractors to bid on a project among our respondents. As with lowest responsive, responsible bidder procurement, the agency solicits bids by publicly advertising the project and identifying the qualifying parameters. The process includes short-listing contractors by qualifying potential bidders with requirements such as attendance at pre-construction meetings, allowing only invitees to participate, or sending a request for qualification (RFQ) only to contractors pre-qualified for bidding.

For example, the University of Minnesota has established a list of 84 contractors who are pre-qualified depending on the nature of the project. By doing so, the University has eliminated an often time-consuming process for answering the question “whom to ask?” To qualify with the University’s PIPS system, a contractor must respond to a request for qualification to do work generally, not necessarily for a specific project. What this process aims to do is provide a “filter” as the first step in the process, requiring specific information about past projects and specific performance thereon. References and surveys answered by up to 25 of the contractor’s previous clients about the contractor’s management and subcontractor relationships form the basis of this filter, and the score derived from the responses becomes one element worth 15% of the final project scoring formula. This “record” is updated with each project the contractor completes for the University.<sup>1</sup>

The key to best value procurement is that the procuring agency identifies that the bidding process will use a best value process where experience is weighted, along with other filters, at a significant measure to price. The formulaic criteria should be identified so the contractor can properly weigh its experience against the requirements of the project. Caution is recommended in identifying which criteria will be evaluated. The City of Eagan was advised by its attorney not to include the contractor’s history of initiating change orders or the contractor’s history of complaints regarding completion deadlines or the quality of its work.<sup>2</sup> The reason for this is a perception that change order history can be very misleading, and is a legitimate form of contract adjustment when the plans, typically not prepared by the contractor, are found to be deficient.

---

<sup>1</sup> Nacole Kaai, best value presentation, September 17, 2008.

<sup>2</sup> John Gorder and Russ Matthys, interview, October 23, 2008.

Similarly, the schedule is often influenced by circumstances beyond the contractor's control, and should therefore not be judged negatively.<sup>1</sup>

This caution is certainly well founded, but each agency will need to find its own criteria and measure the value and importance of the criteria against the objectives of the project. Above all else, the entire solicitation process under best value is intended to gauge *relevant similar* experience, and was demonstrated repeatedly by our agency respondents.<sup>2</sup>

For additional research into solicitation, the reader is advised to review the National Cooperative Highway Research Program (NCHRP), Synthesis 38 (2001): *Quality Based Performance Rating of Contractors for Prequalification and Bidding Purposes*, and Synthesis 390 (2009): *Performance Based Construction Contractor Prequalification*, which identifies an effective system as one that “furnishes an incentive for good contractor performance, while influencing marginal contractors to improve their performance to remain competitive in the industry, and adds value to the completed construction project.”<sup>3</sup>

### **Qualification**

Definition: *the means for certifying contractors to bid on a project*

It is one thing to solicit contractors to bid on a project, but it is another to measure and qualify their experience and ability to handle a specific project. As with solicitation, the qualification process attempts to determine the experience and ability a contractor has to successfully complete the project. The difference is that solicitation makes the *global* inquiry; the qualification process makes the *specific* inquiry. By “specific” we mean “specific to the criteria established by the project.”

One of the perennial challenges with lowest responsive, responsible bidder is that the solicitation and qualification processes are too closely linked to basic conditions, such as the ability to post a bond. We often heard from our agencies a frustration with a contractor that in every respect can meet the basic criteria, such as bonding, but executes only to the level necessary to meet the minimal project requirements and is very difficult to work with. Thus, these contractors can and will repeat bidding, and winning, additional projects and also repeat the frustrations.<sup>4</sup> Agencies have been very reluctant to exclude marginally performing contractors from bidding and winning repeatedly from the same agency, perhaps out of fear of legal challenge.<sup>5</sup>

However, it must be noted that construction documents will prescribe basic performance criteria, such as accomplishing a specific result, without stipulating how that result is to be achieved.

---

<sup>1</sup> Also cited in Thomson, et al., footnote 159: “. . . the contracting entity cannot consider a proposer's claims history.”

<sup>2</sup> See also “Of Filters and Formulas” later in this report.

<sup>3</sup> Available online: <http://www.trb.org/CRP/NCHRP/Publications/NCHRPReports.asp>

<sup>4</sup> Russ Matthys, City of Eagan, interview October 23, 2008.

<sup>5</sup> According to Mr. Dean Thomson, agencies do have the ability to disqualify underperforming contractors, but rarely exercise their authority to do so.

Traditionally, means and methods have been the province of the contractor, and correctly so, but the documents do not, and probably cannot, prescribe how the owner should “feel” about the process. Measures of owner satisfaction have traditionally not been part of contract documents due to the difficulty of creating them. One needs to ask if there is anything “wrong” with lowest responsive, responsible bid and underperformance of a contractor. Even though poor workmanship was corrected, the schedule was delayed, and liquidated damages paid, if the job got done, has the taxpayer been well served, regardless of the frustration it took to get there? That is the fundamental question that best value attempts to answer—how to get the best performing contractor on the job? The private sector has long solved this problem by simply refusing to work with an underperforming contractor. The job might get done, but if the private sector owner does not feel good about the process, there is simply no sense in suffering again on another project with this contractor.

The 2007 legislation permits the agency to evaluate “the quality of the contractor’s performance on previous projects,” as well as timeliness and customer satisfaction. The agency is allowed to establish criteria the contractor must meet. This process is critical to the success of the project. The criteria include the following:

- Past performance proves the firm is dependable.
- It has engaged in this specific type of work before.
- It is large enough to handle the scope of this project.
- Its financial history shows it is stable and liquid enough to maintain operations for the duration of the project.
- An interview proves the key players are capable and willing to work as a team.

Qualification is therefore a key “filter” in the best value process, and one that should be taken very seriously. Any best value process needs to consider the goals and objectives of the specific project and tailor the qualification questions to *best* respond to the objectives, preferably with as little subjective evaluation as possible.

### **Qualifying: of Formulas and Filters**

To measure, one must formulate. The variables within the formula are the filters, representing the “what” of measurement. Consistently across all agencies reviewed was the establishment of a formulaic approach to determining the best value contractor. Indeed, the legal basis of the 2007 law is consistent in requiring a formulaic measurement that includes the non-exclusive filtering criteria without specifying the weight each must allow, but not require, in the formula:<sup>1</sup>

- Quality and timeliness of the contractor’s performance on previous projects
- Level of customer satisfaction
- Ability to minimize change orders
- Ability to prepare appropriate project plans
- Technical capability of the contractor
- Experience and qualification of the contractor’s personnel
- Ability to minimize risks

---

<sup>1</sup> Minn. Statute §16C.02, as cited in Thomson, et al., pg. 48.

A simplified best value procurement process can be illustrated as follows:

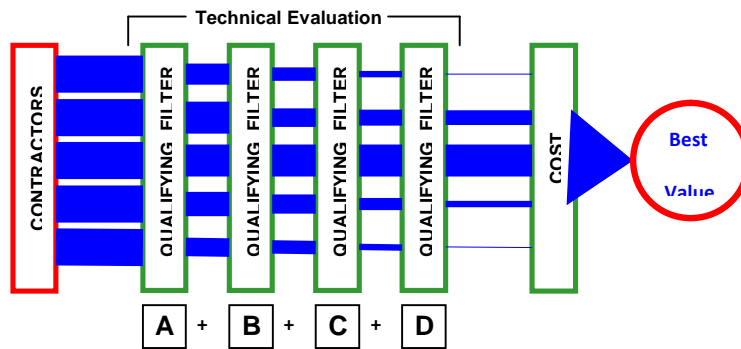

Figure 1. Best value procurement process diagram

The differences in approach to the formulaic basis by the various agencies lie primarily in the filters used to measure and qualify. Following is a brief snapshot of the formula and/or filters used by the various agencies examined:

MnDOT I-35W Bridge

Best Value = [Price + (Duration in Days \* \$200,000)]/Technical Score  
 (Also known as (A + B)/Technical Score<sup>1</sup>)  
 Where \$200,000 is 50% of the determined daily economic cost to taxpayers  
 Quality: 50%  
 Aesthetics / Visual Quality: 20%  
 Enhancements: 15%  
 Public Outreach/Involvement: 15%

University of Minnesota PIPS for CPPM Projects

Price: 20%  
 Performance: 80%  
     Interviews: 25%  
     RAVA Plan: 25%  
     Past Performance: 15%  
     Schedule: 5%  
     Equal Opportunity: 5%  
     Safety: 5%

The Minnesota Department of Administration Transportation Building:

Price: 60% (weighed against competitors)  
 Criteria: 40%  
     Project Approach, Work Plan, Schedule  
     Contractor and Subcontractor Experience  
     Personnel Experience  
     Safety

---

<sup>1</sup> At the time of this writing, A+B determination (cost + time) is being considered for revision in the current legislative session (H.F. 1815) wherein a time factor adjusted by a lost economic value could not be used to adjust the bid price, but could be established by the commissioner as a criterion within the RFP document, such as an element within the technical score.

### The City of Roseville Ice Arena

Price: 25%  
RAVA Plan: 25%  
Interview: 20%  
Past Performance: 20%  
Schedule: 15%

### Regions Hospital Expansion

Design-Build Team Experience: 20%  
Personnel Strength: 20%  
Project Understanding; 20%  
Schedule and Approach: 15%  
Differential Advantage: 10%<sup>1</sup>  
Fees: 15%

### Ballpark Authority

Cost: 50%  
MBE/DBE Participation: 15%  
Experience: 15%  
Current Workload: 20%

When comparing the various agencies, their weighting schemes are a reflection of the project priorities. Weighting is determined by each agency to suit the specific demands of the project, and rightly so. Any shift in weight not only shifts the priority, but will also change the selected contractor. Price, the most significant factor in lowest responsive, responsible bid, ranges under these best value scenarios from 20% to 60%. A contractor with the low price fares better when price is more heavily weighted than experience. What is consistent in these examples is the focus on experience, personnel, and the project work plan, usually in greater proportion to price.

It should also be noted that within each of these broad weighting parameters, there are several sub-parameters that make up the whole. For example, under the MnDOT scheme quality was worth 50% of the total score, but within the quality parameter were nested several sub-categories measuring experience, key individuals, quality assurance/quality control, safety, and performance measurement. Each of these sub-categories also requires a weighting system, along with rules for *how* these criteria are to be measured.

Several respondents felt that with a future project the weighting and the filters might be adjusted differently. For example, the Minnesota Department of Administration felt that 60% for price was too high, and the 40% designated for experience and the work plan needed to be tightened up to narrow the responses into a more measurable range.<sup>2</sup> Further, the use of “pre-qualified lists” also varied. The University of Minnesota uses them extensively, while the Minnesota Department of Administration avoids them, believing there to be “too high of a potential for claims and challenges with a pre-qualified list versus qualifying bidders on a per project basis.”<sup>3</sup>

---

<sup>1</sup> “Differential Advantage” was a criterion used to weight one proposer over another based upon overall responsiveness and compatibility with Regions objectives.

<sup>2</sup> Christofferson and Waslaski, Minnesota Department of Administration, presentation, October 15, 2008.

<sup>3</sup> Christofferson, document review, March 23, 2009.

Best value scoring can be accomplished using a variety of different formulas or algorithms. At its most fundamental, the simplest algorithm is this:

$$\text{Best Value} = \text{Price} / \text{Technical Score, or}$$

$$\text{Best Value} = (\text{Price} + \text{Time Cost}) / \text{Technical Score} \quad (\text{also known as A+B scoring})$$

Where price or (price + time) costs are hard, defined values or intervals, and technical scores can have soft, subjective intervals. Time is measured in cost as a user value per diem.

One of the concerns with A+B scoring was the inclusion in the technical score of many “soft” subjective measures, such as the “aesthetics” or “public relations” of the I-35W Bridge. Subjective and objective measures were given essentially equal weight. Alternative algorithms could adjust for this.<sup>1</sup>

$$\text{Best Value} = A(x) + B(y) + C(z)$$

Where A, B and C are the rating components, such as cost, time or technical score, and x, y, and z are the weights measured as a percentage totaling 100%

or

$$\text{Best Value Fixed Price} = \text{Highest Technical Score}$$

One concern raised was the issue of “outliers,” those proposals more commonly referred to as “out in left field” from a cost perspective and for which the scoring algorithms do not reflect this disparity of the proposed costs. Theoretically, as happened with the I-35W Bridge, the best value can also be the highest cost without adjusting for the highest cost as an objective measure. If the lowest cost for the highest quality is a desired objective, then a means to measure those proposals against each other seems a reasonable proposition. Consider, then, a weighting system as follows, wherein each proposal is measured against the lowest cost:

	Contractor A	Contractor B	Contractor C
Proposal:	\$900,000	\$1,000,000	\$1,100,000
Factor:	$\frac{\$900,000}{\$900,000}$	$\frac{\$900,000}{\$1,000,000}$	$\frac{\$900,000}{\$1,100,000}$
Factor:	1.00	.90	.82
If weighted 50%	.50	.45	.41

This methodology uses price as a weight, but factored against the low cost proposal.<sup>2</sup> This still means that a high-priced contractor can be the best value based on other technical scoring measures as part of an overall algorithm. However, the price will now have been factored to reflect disparity. A system of treating the highest and lowest prices—the outliers—should also be considered so as not to burden the factor with an unreasonable disparity. One possible consideration may involve evaluating all proposals based on an average or median disparity of one proposal in relation to the next highest and lowest proposals.

---

<sup>1</sup> MnDOT, *Approaching Best Value*, Office of Construction and Innovative Contracting.

<sup>2</sup> Attributed to Mr. Robert Sands, PE.



## **Transparency and Neutrality**

Definition: *Maintenance of an open, fair, and unbiased approach prior to the award of a contract.*

Think of the blind taste tests on TV, where a product is compared with its competitors. At its most basic level, this is transparency and neutrality—a form of blind justice that knows no other influences but the opinion of the taster. The concept of transparency and neutrality is born of the same origins as lowest responsive, responsible bidding, which is a means for public agencies to acquire services without the historical tradition of graft, influence peddling, and outright bribery of public officials by unscrupulous vendors. In other words, the “number” stands for itself and is easily marked as a “line in the sand” against which all proposals are measured. Public procurement has certainly improved over many years, to the point where low bid is hard to unseat as the sole procurement method. The concern of some is that best value has the potential to be subject to influence peddling and favoritism, which is why the process must seek the highest possible standard of fairness when being deliberated and evaluated. Design competitions usually are similarly structured and have successfully compared proposals on merit rather than influence.

So the question is: How can best value, with its inherent element of subjectivity, be as transparent and neutral as possible to avoid litigation on procedure? The process is not new. Design competitions have successfully gained public confidence, ensured integrity of the process, and compared competitive, highly subjective proposals on merit rather than influence. In its simplest form, it is the multiple envelope solution—proposals contain no information as to the maker (lest they be disqualified) in an inner envelope, and are assigned a number or other neutral marker, contained within a discarded outer envelope, to certify submission by the maker. Arguably, the submissions can often contain “signature themes,” especially in design, that may be widely recognized as belonging to a known proposer, such as a particular building or trademarked process, so it is not always possible to be absolutely blind.

## **Pre- and Post-Proposal Process**

We found that agencies use a two-tier system for best value procurement, basically defined as pre- and post-proposal. Those activities occurring pre-proposal submission are focused largely on the proposer and include the entire qualification process, meetings held during the preparation stage, correspondence, e-mails, and addendums. Post-proposal submission activities are primarily focused on evaluation procedures that mainly concern the agency’s internal process. In either case, procedures must be rigidly applied and maintained to retain transparency and neutrality. Three basic concepts should be considered:

Separation: of information and identity

Isolation: of people and communication

Timing: when disclosure of critical information is released

For example, with the MnROC 52 project, the first MnDOT design-build project, the contractors were known to MnDOT during the technical review stage, but their pricing information was not. During the I-35W Bridge reconstruction project, the process was strictly structured to limit contact with the agency to specific, equally distributed times and specific agency staff, so that the communication chain could be tightly, centrally, and systematically controlled and maintained. Evaluators heard testimony from internal or external experts as a group, but were isolated during the technical scoring process, with no internal contact except with a single agency representative to answer questions. The entire process was supervised by a process

oversight committee. During contractor interviews and the technical review phase of the process, the evaluators had no knowledge of the contractor's cost or schedule, so that these factors would not influence their evaluation in any way. It was not until the technical evaluation panel had completed the review of the proposals and technical scores had been tallied and certified that the information on cost and schedule was released and subsequently plugged into the formula to determine a winner.<sup>1</sup>

On paper, this appears to be a relatively blind approach that would stand up to public and legal scrutiny. Why, therefore, was the process for the I-35W Bridge award challenged in court? Essentially, it was the high disparity of scores between the winner, Flatiron/Manson (91.47), and the three other proposals (67.88, 65.91, and 55.98). Given this disparity, the petitioners claimed the process to be unfair on a key point. The RFP had required the bridge not exceed right-of-way restrictions. However, the winning proposal by Flatiron exceeded the right-of-way restrictions and was thus not responsive to the RFP, but nevertheless received a higher technical score. The other bidders had evidently been advised that their designs must respect the right-of-way restrictions. They then claimed that certain "oral" communication that occurred pre-proposal was not converted into writing that would have been consistent with a traditional request for information procedure or in accordance with MnDOT's own procedures, was not shared with all proposers, and further that such action had created an unfair advantage.<sup>2</sup> Had the scores been closer, there likely would not have been litigation to challenge the award. It should be noted that the entire selection process stood up in evaluation by the Federal Highway Administration (FHWA), the Government Accounting Office (GAO), and the HHS Office of Inspector General. (These agencies were involved because federal emergency funds were used.)<sup>3</sup> However, it is relevant to note that this review was completed prior to discovery of the facts and grounds for the protest. Ultimately the Minnesota Second Judicial District Court denied the legal challenge, which, as of this writing, has been appealed to the Minnesota Appellate Court. What the entire litigation addresses is primarily the *process* of selection, not the concept of best value procurement.

### **The Evaluation Team and Transparency**

The legal challenge did cast doubt on the composition of the evaluation team. Team composition can make an extraordinary difference in the result. Fundamentally, an evaluation team should be composed of people thoroughly knowledgeable in the technical and programmatic aspects of the proposed project. The technical evaluators can compare proposals on their merit in meeting the physical, scientific, or engineering requirements of the project, while the programmatic evaluators represent the "stakeholders" in assuring the owner and/or taxpayer that the proposal fulfills the project objectives. Further, the 2001 design-build legislation requires that one designated member of the Associated General Contractors (AGC) be part of the review panel, presumably as a "stakeholder."<sup>4</sup> The I35-W Bridge evaluation team

---

<sup>1</sup> MnDOT proposal evaluation plan, Sept 13, 2007. See also Ward, MnROC 52 case study previously cited.

<sup>2</sup> Disclosed by Mr. Jeff Wieland of Fabyanske, Westra, Hart and Thomson, PA , representing the plaintiffs in the legal roundtable discussion held October 1, 2008 and including Mr. Tom Vollbrecht of Faegre and Benson, representing Flatiron/Manson; and Mr. Richard Varco, attorney with the Minnesota attorney general's office, representing MnDOT. Further clarified by Mr. Dean Thomson, April 3, 2009.

<sup>3</sup> Mr. Terry Ward, assistant project manager for MnDOT, presentation notes, September 10, 2008.

<sup>4</sup> Minnesota Statute §161.3420 subdiv. 2, as cited in Thomson, et al.

consisted of four representatives from MnDOT, one from the City of Minneapolis, and one from the AGC.

As no proposal is perfectly clear in its written form, an interview is typically used to clarify aspects of the proposal. This is a critical stage in the process where issues of transparency and neutrality can easily break down. One criticism of the bridge evaluation process was the interview, in which the technical review panelists participated in a joint interview with the proposer after meeting jointly to develop questions.<sup>1</sup> While the proposer could not enhance or add items to its proposal, this did give an opportunity to be influenced by what the other panelists said and by the responses of the proposer. It was after these interviews that the technical review panel scored the proposals—individually and in isolation.

So is this wrong? Ironically, it is a process that in its most fundamental form is followed by most agencies in their selection process: receive proposal, read, interview proposer, talk among your peers, make a determination jointly or individually, and vote on it. While the process is not wrong per se, it is the Achilles heel of the transparency question since influence, however innocent, can occur among the panelists themselves as well as between the panelists and the proposer.

How can this be solved, at least theoretically? In the case of MnDOT, a non-voting project facilitator knowledgeable about all aspects of the project could have been used to screen the technical review panelists from each other and the proposer by requesting their questions, conducting the interviews, delivering the responses uniformly to the panelists, and enabling them to independently assess the proposals in complete isolation. In many ways, the panelists in this scenario are like jurors—they cannot ask questions in court and can only listen, taking the information presented to them by others and making their determination jointly.

This is an entirely workable, theoretical approach, but some will argue that it lacks practicality, especially for boards lacking in experience, and can add considerable time to the process. Further, there is a definite synergy among technical panelists when making evaluations—gaining knowledge from others with experience is at the root of learning and understanding. Indeed, Socrates would be unknown if he could not have asked questions and, essentially, raised doubt, the key to gaining understanding. True separation—transparency—could occur between proposer and panelists with a knowledgeable non-voting intermediary conducting the interview and a retreat by the panelists (after satisfaction that all “questions” have been answered) to vote by some form of written, accountable balloting system. In defense of MnDOT, its proposal evaluation process was an attempt to be as transparent and fair as possible, was developed after the experience gained from many previous projects, and is worthy of emulation, if not also refinement, to reflect the real challenges to its process.

The bottom line for agencies is that evaluation teams are subject to the transparency question, both internally and externally, and that maintaining transparency is the key to achieving the objective of being fair. The processes used must be closely developed, managed, and tested, with advice from agency counsel, to withstand the deserved scrutiny of the public and the courts.

---

<sup>1</sup> Legal roundtable discussion held October 1, 2008, previously cited.

## Subjectivity vs. Objectivity

As mentioned earlier, many design competitions have been determined to be blindly transparent, even though design elicits a subjective, if not purely emotional, response that cannot be easily quantified or measured. Indeed, any criterion requiring a subjective response can raise the level of public scrutiny and disagreement about something that is truly in the eye of the beholder. All one need do is look back to the Vietnam Veterans Memorial in Washington, DC, the competition for which electrified the nation and resulted in an iconic and striking monument whose simplicity and audacity can hardly be argued. So the question is: Can best value procurement work satisfactorily where subjectivity is required?

Once again, we turn to the I-35W Bridge to gain an understanding. This was a design-build delivery method, which means basic design criteria—get from point A to point B—were given in the request for proposal, but the final design, including whether constructed of steel or concrete, was the responsibility of the proposer.<sup>1</sup> Had the bridge been fully designed, then the subjective questions of aesthetics would have disappeared from consideration. However, the design of the bridge was worth 20% of the score, and the design solutions proposed were each significantly different. Understandably, the scoring may have reflected this. One of the primary arguments from the legal challenge arose from the fact that the written comments on the ballots did not match the score given—the same “good” comment was given to both teams, but a lesser score was given to one of the teams. Mr. Rick Varco of the Minnesota attorney general’s office (representing MnDOT in the challenge) stated, “You cannot have a precise correlation between scores and words,” and went on to cite the analogy of recent Olympic scoring in Beijing, itself steeped in controversy, wherein judges “hold up numbers based on opinion without justification.”<sup>2</sup>

The other area of controversy on the bridge was the scoring for “public relations plan,” worth 15% of the score, an area in which true quantitative analysis is hard to come by. Was this a valid criterion on which to base scoring? Should it have weighed so heavily in the scoring formula? This was largely a judgment call, and a response to the criterion set forth by MnDOT that the public relations on this project would be of significant importance, given the tragic circumstances. One could debate whether or not it was truly appropriate,<sup>3</sup> but the point is that

---

<sup>1</sup> Author’s note: This is a relevant distinction that bears discussion. Mr. Dean Thomson has argued that had the design criteria specified a concrete structure, then four competitive proposals could have been received and saved the taxpayers tens of millions of dollars. He goes on to state that through their discussions with the proposers, MnDOT “signaled” steel over concrete as the apparent preference by MnDOT, and thus three of the four proposers pursued steel over concrete with their bids. MnDOT has argued that given the time constraints, they did not specify steel or concrete, would have accepted either, though concrete would always be preferred as a more favorable solution, and expected that the length of the clear span over the channel would likely preclude consideration of a concrete span due to technical and time constraints. The fact that the Flatiron/Manson/Figg team solved the technical challenges by proposing an in-situ post tensioned pre-cast box girder structure is testament to the creativity design-build approaches can bring. Their solution was a technical concept accepted by MnDOT, and not shared. See “Protection of Ideas” below.

<sup>2</sup> Legal roundtable discussion held October 1, 2008, previously cited.

<sup>3</sup> Author’s note: No one would likely argue the necessity of a good public relations plan given this particular extraordinary circumstance. However, Mr. Dean Thomson has argued that the PR weighting resulted in a large price distinction. The cost of the “competing” PR firms, he notes, was comparable, but the point differential in the scores equated to millions of dollars for each point. Thomson continues that if the PR had cost \$1 million for each proposer, should the difference in scores have accounted for about \$10 million in cost between the proposals? This could theoretically have been solved by specifying an allowance of \$1 million, and perhaps rating the specifics of the competing plans without cost being a factor. Perhaps a lesson learned.

the agency must establish the criterion initially that is to be measured and determine a means to measure it as quantitatively and simply as possible, with the least amount of subjectivity. Subjectivity is unavoidable in many circumstances, and is supportable by the law. Indeed, Mr. Varco further pointed out that there was nothing done during the evaluation that was contrary to the law, and that the subjective decisions were neither arbitrary nor capricious.<sup>1</sup>

During the legal roundtable, Mr. Jeff Wieland, of the Fabyanske law firm representing the taxpayers, was repeatedly challenged on the efficacy of the ongoing litigation but characterized the challenge as a means to improve the process of award, not an attempt to stifle the use of best value. His suggestions reflect possible improvements that should be considered by any agency contemplating best value:

- Provide for individual scoring without opportunity for collusion.
- Maintain a balanced technical review committee.
- Establish criteria as objectively as possible—“black and white”—and avoid subjective criteria.
- Let “requirements” define responsiveness.
- Provide detailed comments that tie into scoring, i.e. “I deducted half a point for . . . “
- Provide full public review before award, stating, “Sunshine is the best disinfectant.”<sup>2</sup>

### **The Protection of Ideas**

Considering the question of fairness, it is a long-held frustration in the industry that “ideas”—those suggestions regarding improvements or alternatives that arise from contractors—have not been fairly received and have stifled the creative process. Contractors have traditionally held out alternative ways of delivering project requirements, but because of the requirement for fairness and transparency under the lowest responsive, responsible bid process, have held back. Any suggested alternative has typically been presented during the bidding phase, and once accepted by an agency, must be issued to all bidders as a bid addendum to result in a “fair and balanced” bid process. There has traditionally been no incentive for the contractor to make suggestions when its suggestions support the winning bid of a competitor who did not initiate the idea. Often, the idea was held close to the vest, and re-surfaced only after award and contract as a voluntary alternative to be considered by the agency.

MnDOT recognized this under its first best value project, MnROC 52, using a few strategies. All losing proposers were offered a fixed stipend to cover their costs and efforts in putting a proposal together, which could include alternative technical concepts (ATCs) to the suggested standards. These were kept under wraps and not distributed to other proposers, and served as the competitive advantage when the technical evaluation was completed. Only after an award was made did MnDOT say that any proposals tendered by a losing firm be considered by the winning firm since, by virtue of the stipend, MnDOT had “acquired” the ideas.<sup>3</sup> There is no question that this alternative technical concept approach not only spurred creativity, but also generated cost savings that kept the project below the budget. Further, the stipend, if accepted by the losing firm, contained a surrender of claims clause.

---

<sup>1</sup> Legal roundtable discussion held October 1, 2008, previously cited.

<sup>2</sup> Ibid., legal roundtable. Quote attributed to Justice Louis Brandeis.

<sup>3</sup> Ward, MnROC 52 case study, previously cited.

Both design-build and design-bid-build delivery methods have the opportunity to consider alternatives, even encourage them in a fair way. Ideas are normally the province of the design team, but since the design team rarely has precise access to either the kind of cost data or the “means and methods” that contractors have, with project decisions so often rooted in cost, the need for cost-effective creative options has never been more relevant. Agencies should encourage ideas, but should protect them and deal with them in an open and fair manner, and find a way to “own” those ideas, even if a stipend is required—which could be far less than the savings they may generate. To be fair, the encouragement, management, and protection of ideas *must* be advertised during the pre-proposal phase, and carefully protected during the post-proposal evaluation phase.

### **Fairness When Sources of Supply Are Limited**

What of the truly unique project that has few sources of supply? Can fairness in the procurement process be maintained? The short answer is yes, but it does become more challenging.

Consider the case of Roseville Parks and Recreation, which sought to replace the cooling system for its aging ice arena. Such a request is generally not all that unusual, except when there is a requirement that the system be geothermal. While geothermal systems are becoming popular, larger applications of geothermal systems are not as prevalent, nor are there many contractors that have direct experience in geothermal systems for ice arenas. According to Lonnie Brokke, director of parks and recreation for the City of Roseville, “We were really concerned about [the fact] it was very limited in terms of contractors that were out there that could really do it, specifically for ice facilities. Geothermal was out there for a long time, but in ice facilities it was relatively new. We didn’t want to have to go to low bid. We want to be able to choose somebody who has had a lot of experience, who has had a history [with geothermal on ice arenas].”<sup>1</sup>

To solve their problem, Brokke and his team cast a wider net, seeking referrals from the University of Minnesota and a Canadian geothermal consultant on the project. They ultimately received five solicitations and three proposals, a number sufficient to continue the process.

So what if no one can respond, because of lack of experience, an important filter in best value? It is safe to presume that there are very few projects being contemplated that would have this problem, but it is conceivable. The owner/agency needs to understand that the fewer sources of supply that are available for a project, the more risk from lack of direct experience the owner will have to accept during the construction of the project. So to answer the initial question about no response, the filters need to be modified until a reasonable quantity of proposals can be fielded. The filters would have to rely less on *direct* experience and more on *parallel* experience, such as dealing with similarly complex projects. Highly qualified contractors that may not have direct experience can be located for a project, but they may instead have the experience to think through a project and its unique challenges and logistics. The additional risk for the owner, albeit minor, would likely result only from changes in conditions that were not foreseen in the risk assessment, pre-proposal phase.

---

<sup>1</sup> Lonnie Brokke, interview, October 1, 2008. See also the Appendix.

The private sector has long recognized this risk, and tends to exercise the team approach—“we’re all in this together”—between the designer, contractor and owner. There are also notable disasters that can be cited, but the key to success is the risk assessment phase of the procurement process, to “build the project in one’s mind” and conceive of all possible risks in order to minimize the potential for disaster. For an agency that has limited practical experience, the retention of a qualified construction management consultant to assist the agency would be a way to sort through the myriad of possibilities and risks the project entails. The expenditure of funds wisely disbursed during the planning stages of a project can yield big dividends in its execution.

### **Delivery Method**

Definition: *Impact of design-bid-build, design-build, and construction manager at risk on the use of best value procurement.*

Best value procurement knows no boundaries when it comes to the method of project delivery. Based on the results from the agencies reviewed, it has been used for traditional design-bid-build, design-build, and construction management, both agency and at risk. Since it is a procurement method, the techniques are equally successful when applied to any delivery method; however, the important aspect for agencies to recognize about the delivery method when using best value is to specify the process in the request for qualifications and/or the request for proposal. The nature of the delivery method does affect how a contractor will price its proposal, and there may be costs associated with the “rules” by which the contract will be managed.

The tougher question related to delivery method affects not the contractor, but the owner/agency, and that question is, when to decide which delivery method is best for the job. That question is not the province of this research, and these decisions have frequently left agencies in a quandary as to how the best method is to be determined. As was mentioned earlier, the Association of State Departments of Transportation has developed the following list of objectives, in order of priority, for determining when to use design-build:

1. Shorten duration.
2. Establish schedule.
3. Reduce claims.
4. Support constructability.
5. Establish cost.
6. Support large/complex project.
7. Reduce cost.

It follows, therefore, that a project whose primary objective is lowest cost would not be a candidate for design-build. But as each project is in some respect unique, to a lesser or greater degree, then consideration of the right delivery method for the objectives of the project becomes of paramount concern.

The reader should consider additional research into alternate project delivery in the National Cooperative Highway Research Program (NCHRP) Synthesis 561 (2006), *Best Value Procurement Methods for Highway Construction Projects*.<sup>1</sup>

---

<sup>1</sup> Available online: <http://www.trb.org/CRP/NCHRP/Publications/NCHRPReports.asp>

## **Risk**

Definition: *Project risk management for the owner, comparing best value procurement to the traditional lowest responsive, responsible bidder process*

Risk is defined as a “chance of harm or loss.” Typically, risk implies danger; however, risk also is more recently associated with opportunity. In other words, risk can be positive or negative. So the definition might be modified to read: “a chance of harm or loss, or a chance for opportunity and gain.”

Risk is also dependent on magnitude, perception of value, and time. The magnitude can be described as follows: disastrous, severe, substantial, moderate, marginal, or negligible. The value-based descriptors are more concerned with the likelihood the risk may occur—essentially a value judgment, and can be described as follows: highly likely, likely (>50-50 chance), somewhat likely (<50-50 chance), unlikely, very unlikely, and extremely unlikely. Most of these descriptors are intuitive, and we all consider these when planning a project, but best value should, as a regular course or habit, force consideration of all the risks of the project, and whether to quantify or qualify them. It should then factor them in as part of a risk assessment plan.<sup>1</sup>

How to manage construction project risk? That question is at the core of best value procurement. Ultimately, every owner/agency, public or private, retains the project risk since the completed project benefits the owner. This means that ultimately any costs, delays, and quality issues—the time/cost/quality constraint—are “owned” by the developer of the project. The owner delegates portions of the project risk to contracted parties best able to manage this project risk on behalf of the owner, such as the architect/engineer and the contractor. The more that can be delegated, the less apparent risk the owner absorbs, but the owner’s risk is never fully absorbed by others.

Delegating the construction risk and, to a lesser degree, the design risk (as in a design-build delivery method) is the focus of best value procurement, and in a perfect world the owner assumes no responsibility for the construction risk of a project, except that which is truly unforeseen or unknown. The transfer of risk back to the owner is revealed by the prevalence of cost increase through change orders, schedule delays, and disagreements over quality issues. These are often the result of errors and omissions on the plans resulting from the delegation of the design risk to the design team. The level of construction risk delegated or retained by the owner is limited by the content of the construction documents and the construction contract.

No risk, no reward, as the adage goes. Risk translates into cost on so many levels. The more risk delegated, the more costly the project. Where cost is of concern (as it usually is) the goal of the owner/agency is to delegate as much of the project risk as possible to those best able to manage the risk and retain only that portion of the project risk that the owner/agency can readily manage or control. And in delegating the risk, the owner expects to satisfactorily mitigate the risk at the lowest possible cost without a sacrifice to quality or schedule.

---

<sup>1</sup> A. AbouRizk, Ph.D., PEng, *An Overview: Risk and Uncertainty in Construction*,” University of Alberta, [www.construction.ualberta.ca/Papers](http://www.construction.ualberta.ca/Papers)



Best value is based on the premise that the contractor with the most experience is best able to recognize and address project risk(s) and execute the project with the least residual risk impact to the owner/agency manifested in the form of cost increases and schedule delays. Therefore “best” can essentially translate into “least risk to owner,” recognizing time, quality, and cost as integral to the risk axiom.

How does best value achieve this? To examine this question, it helps to understand the sources of project risk. Consider a typical risk uncertainty curve, wherein the amount of project risk decreases exponentially the more information is known about a project, usually as the design documents progress to completion. The information that is undetermined about a project at any given moment in the life of a project can be broken down into three basic classifications:

- Those that are *known knowns* (and fully quantifiable = the design)
- Those that are *known unknowns* (and not quantifiable = contingency)
- And the *unknown unknowns* (not identified or quantifiable = surprise!)<sup>1</sup>

It is the known and unknown unknowns that cause the problems for projects if not properly managed. The objective of best value procurement is to *identify* the known unknowns and to *speculate* on the unknown unknowns and develop management strategies for dealing with these, should issues arise. By way of example, on the I-35W Bridge project, MnDOT accepted the potential for contaminated soils in its request for proposal. This was clearly a known unknown—MnDOT knew the site was contaminated but, due to the enormous time constraints to start, did not have time to fully investigate. It also knew that, one way or another, the cost to mitigate these soils would ultimately be borne by MnDOT, whether directly if self-performed or indirectly if performed by the contractor. By accepting this risk and agreeing to pay for the cost of mitigation, MnDOT was able to eliminate the uncertainty the contractors would harbor in their bids, which customarily results in higher bids, not to mention the markups the contractor would likely apply. The effect was saving additional taxpayer expense.<sup>2</sup>

The Minnesota Department of Administration used the contractor interview process when presenting its work plans as one tool to sort out risk. As a result of this process, the department discovered that a contractor had not adequately considered the owner’s occupancy when developing the process for inserting new columns within the building structure. The plan proposed would have severely disrupted the agency’s operations. Had that situation not been discovered, it would have certainly elevated the costs and likely resulted in a schedule delay. As it turned out, this contractor was not awarded the project, since the winning contractor had considered this obstacle, among other things, within its work plan.

The unknown/unknowns are harder to deal with since they are truly surprises. Hopefully, with proper planning and foresight, the extent of the unknown unknowns will be minimized. The strategy for dealing with them is retaining a budgetary reserve to cover these unexpected costs, having flexibility to reduce scope to maintain budget, and most importantly, defining a process for dealing with them (i.e. unit cost, time, and material) in the risk management plan.

---

<sup>1</sup> Valerie K. Svennson, MnDOT, *Integrating Risk and Uncertainty in Project Planning*, U of M Infrastructure Systems, engineering capstone presentation, March 9, 2007.

<sup>2</sup> Ward, MnROC 52 case study, previously cited.

The University of Minnesota RAVA plan gets directly to this issue of risk mitigation by presuming that no one contractor can identify *all* of the risks all of the time, but that all of the bidding contractors can identify *most* of the risks all of the time. By sharing the risks identified in the RAVA plan with the best value contractor, the University assures itself that those best able to identify the construction risks—the contractor(s)—are also the ones best able to mitigate the risks identified in the plan and reflect them in the contract.<sup>1</sup>

All of the other agency respondents had some form of risk mitigation process in place. Both the SoWashCo School District and the Ballpark Authority assigned their risk to a construction manager, using knowledge and experience to help evaluate and represent the owner's risk in the process where the necessary knowledge was not possessed by the agency. The Minnesota Department of Administration and the City of Roseville both used a risk assessment plan similar to RAVA to determine and select a best value contractor.<sup>2</sup>

For agencies considering best value, a form of project risk assessment is a necessary prerequisite to a successful outcome. Where projects are perceived to contain a relatively high amount of risk, best value does force consideration of the risk in advance of a contract. Where a project is fairly routine or redundant, the risk drops significantly, and the more traditional lowest responsive, responsible bidding approach is acceptable, as long as the owner agency considers all the possible risks—the known unknowns and the unknown unknowns—and covers them with appropriate economic contingency.

### **Schedule**

Definition: *Effect of best value on the schedule*

There is an oft-quoted adage in the industry: "measure twice, cut once." The time it takes to double-check the measurement to get it right is far less than the time wasted in replacing an improperly cut piece, not to mention the waste of material.

It is often the point of serious debate, and even litigation, that schedule is more critical than cost, and that the passage of time is a driver of cost. It is well known in the industry that *time equals money*. And often the prime frustration of owner/agencies is not one of cost, but of delay. Therefore, it has become a critical filter in best value procurement to incorporate an element of time and even the way this time will be managed during the course of a project. And as was just mentioned, time is the key driver in deciding whether to use a design-build or design-bid-build delivery method.

There are two prime factors for owner/agencies to consider regarding this time parameter. First, when using time as a filter to qualify contractors, one needs to determine whether the schedule is to be *stipulated* or *negotiated*. Only the owner/agency can decide this, because it gets to the root of its objectives. As an example, the South Washington School District had no leeway in schedule, and had to stipulate a completion date tied to the start of school. On the other hand, the Minnesota Department of Transportation had flexibility to negotiate the schedule focused more on the contractor's most efficient sequencing requirements, and was able to shift its staff accordingly to make workspace available to the contractor. Regardless of how the

---

<sup>1</sup> Kaai presentation, September 17, 2008, previously cited.

<sup>2</sup> See also the appendixes. Each of the referenced agencies considered risk mitigation a key objective, and each handled it slightly differently, with similarly successful results.

owner/agency decides whether to stipulate or negotiate the schedule, it must be stipulated in the request for proposal, along with criteria setting out the expectations, even “rules,” about how the schedule is to be managed.

The second consideration for owner/agencies is to recognize not just the construction duration, but the overall project duration, including the time commitment from the owner/agency, to get the project to the point of issuing a request for qualification. Often, the contractors can control schedule reasonably well if they possess the experience necessary to perform the work. Often, however, it is the owner/agency that has not planned well for the impacts that construction will cause in the form of disruption to its work, especially for projects involving remodeling to owner-occupied spaces.

One of the hallmarks of best value is assessment of risk during the pre-proposal stage. This risk assessment (RAVA at the University of Minnesota) gets to the schedule impacts directly by considering a host of “what if” scenarios. If a certain scenario should occur during the project, the strategy is in place to deal with it to permit the project to proceed in an orderly and timely matter with minimal delay. So often under the traditional design-bid-build process, the construction risks are not fully considered during the design stage, and the owner/agency may have insufficient experience to ascertain what the risks are. A problem develops, and the project is slowed or halted until a satisfactory resolution, and cost, has been put together. What best value demands of the owner/agency is plenty of forethought, which translates into time, *prior* to the issuance of a contract.

So overall, it could be argued that best value saves no time when considering the total project duration, but it permits the construction to be delivered in a more efficient and timely manner and encourages creativity of approach as a direct result of planning. To return to our opening analogy, best value forces the owner/agency to “measure twice” before cutting loose on a contract. Whether or not best value is used, the twice-considered risks of the project are a certain way to reduce construction delivery time, and thus, cost.

### **Time/Cost Relationship**

Definition: *Impact of best value on project delivery—cost and speed*

The ideal: Build the project for the lowest cost and the highest quality very quickly.

The common reality: Achieve two out of the three objectives: time, cost, or quality.

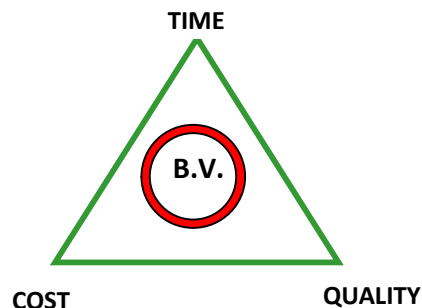

Figure 2. The triple constraint

Best value procurement has as its highest objective gaining the ideal, finding itself at the center of the “triple constraint,” which presumes you can have low cost and high quality but at the sacrifice of having the job done quickly. Or you can have the job done quickly and perhaps at a low cost but with a possible sacrifice of quality. The question is, does best value achieve this objective?

The answer appears to depend on the objectives. Recalling the South Washington County School District, time is of the essence, and therefore a premium may be paid to achieve the objective. Thus the project is perhaps not lowest cost in the true sense, but likely valued appropriately in relation to the goal of timeliness. The I-35W Bridge seems to defy this objective, having been contracted at the longest proposed duration and the highest cost. Its actual duration was eventually within the range of the other proposers, but this was achieved by the payment of an \$18-million-dollar early completion bonus.

The challenge when considering the triple constraint theory is that, though both time and cost are measurable, quality is a bit more ephemeral and more in the eye of the beholder. According to Mr. Gordon Christofferson of the Minnesota Department of Real Estate and Construction Services, “Quality is defined as a less durable or lower lifecycle.”<sup>1</sup> As such, all the agencies reviewed will argue that they have achieved a high-quality result using best value, but would also likely agree that they perhaps did not achieve the lowest cost. The University of Minnesota PIPS system attempts to achieve the triple constraint, and has demonstrated that of 104 projects completed, 51% were still the low bid, and the change order rate was less than 1%; thus the lowest-cost objective was truly achieved.<sup>2</sup> Quality is defined scientifically by the specifications, but more often is *perceptively* measured by issues such as customer satisfaction, wear and tear, and even aesthetics. These are difficult to quantify in formulaic terms, such as in a filter, and may even not be fully realized until well after the project is completed and the contractor fully paid. For the owner/agency trying to use quality as a filter, it is important to maintain perspective on the subjective nature of its evaluation, and remember that the contractor may build very precisely to the specifications and achieve the qualitative measures, but the matter of customer satisfaction, and those other ephemeral qualities that define project success, will be hard to measure and establish filters for.

### **Change Management**

Definition: *Impact of best value on the change order process*

Change is inevitable. Change is one of the leading reasons for best value procurement becoming rooted in the public sector, since it is change orders that have driven costs beyond that which has been budgeted, frustrating and angering owner/agencies. The theory holds that the most change orders will result from poorly qualified contractors performing work with incomplete documents and a low bid. It also holds that a well-qualified contractor can better foresee the challenges of the project and plan for them with fewer change orders and, presumably, a higher bid. These premises are true in both the public and private sector. Therefore, whether change is paid for with change orders or with a higher bid, *theoretically* it should generally result in same cost.

---

<sup>1</sup> Review, March 23, 2009.

<sup>2</sup> Kaai presentation, September 17, 2008, previously cited.

However, the long-standing argument among owners is that future change orders are not reflected in the bidding market in which the original bid was established, leaving opportunities to “gouge” the owner on price, and “make it up on change orders.” While this writer believes that most contractors would rather not deal with change orders, the artificial price inflation potential is very real when change is seen as a business opportunity for the contractor(s).

Is the argument about change orders fueling the trend toward best value warranted? If perceptions about change hold sway, then yes, it is warranted to use best value as a means to reduce change order delirium. But one can also argue that change is less often the result of non-performing contractors and more often the result of poor project management, poor drawings, or both, whether deliberate or not. And what best value achieves is not a true reduction in change order cost, but a better *process* to manage the project and its risks and manage the inevitable change that results. If change orders are to be avoided, risk must be priced, in which case the cost of the project would also presumably rise.

Traditionally, it has been very difficult to achieve a project with no change orders arising from the following three sources:

1. Owner-directed changes
2. Unforeseen conditions
  - a. Contingent (e.g. poor soils uncovered)
  - b. Jurisdictional (e.g. building inspectors)
3. Errors and omissions on the documents

With the first source, we found in many cases that the owner-directed changes were not counted into the project change order determination, because this was the result, in more cases than not, of the owner simply having a change of mind about an aspect of the project (see Scope Management). Thus, this sort of change is completely outside the contractor’s control. This further supports the proposition that the owners also need a process, through better project planning, to manage their side of the change order ledger before it gets to a contract. Thus, most of the change orders that frustrate owners are the result of the latter two sources: unforeseen conditions and design errors/omissions. In our discussion of risk, we identify the risk assessment process that identifies the “known unknowns” and the “unknown unknowns” from which change originates. The key to managing non-owner-directed change in best value procurement is rooted in the risk assessment plan: identifying all the potential “known unknowns” and establishing a plan to deal with them, should they arise. This has been the key strategy at the University of Minnesota in reducing the change order rate from a typical level of upwards of 12% to less than 1%.<sup>1</sup> So even though change is likely to some degree in every project, the means of planning for change is what differentiates best value from more traditional procurement methods. If this planning were not to take place, then one could argue that a change order would likely result.

To trace this thought further, let’s review the risk assessment and value added (RAVA) process at the University of Minnesota. Contractors A, B, and C are each qualified to bid on the project and, along with the bid, complete their risk identification and assessment plan. The best scoring contractor, let us say contractor A, has to review all of the risks identified by contractors B and C and can either accept them without revising its bid, or withdraw. If contractor A withdraws, then

---

<sup>1</sup> Kaai presentation, September 17, 2008, previously cited.

the process repeats with the next best-scoring contractor. The contractors have argued that this puts them in a tough position, often accepting a “risk” that was in fact not well-developed or conceived in the plans without compensation. It is clear to see that this process does significantly reduce the potential for change by mitigating all the known unknowns and establishing a method for resolving unknown unknowns prior to award of a contract. Further, this risk assessment system has also resulted in a greater level of profit for contractors, again likely the result of a better process to manage the project.<sup>1</sup>

It is also well known that the more complexity a project has, the greater the potential for change orders. Likewise, the simpler, more “standard,” the project is, the less the chance for change orders. If this premise is accepted, then the procurement method should not matter, since an owner/agency would presumably plan for more change orders on a more complex project and raise the project contingency. As was often heard during the research, most agencies believed that best value was most successful on projects that had a higher degree of complexity. Remodeling is often considered “complex” since it often involves work around an owner occupant. All of the University of Minnesota capital planning projects identified in the research were remodeling projects, and therefore the success of best value for these types of projects was well documented. However, when evaluating the SoWashCo School District and the construction of a new school, the district did not see the need for best value since, even though the project was very large and incorporated multiple phases, it was not in and of itself complex. The project was suited well to a construction management-based delivery method and has had a relatively small volume of change orders.<sup>2</sup>

One interesting sidebar: MnDOT elected to mitigate the risk of change orders by offering a \$7 million “no-excuse bonus” wherein if no change orders were presented to MnDOT, other than for owner-directed changes (of which there were several, including an access tunnel requested by the City of Minneapolis) or for soil remediation, then the contractor would be paid the bonus. The contractor could make this determination at the end of the job, but if one change order was requested for payment, the bonus would not be paid, and the contractor and MnDOT would proceed to process all the change orders, with an uncertain result for both the agency and the contractor. This provision for a no-excuse bonus does not prevent the contractor from making a claim if a claim is indeed warranted. Nor does it prevent the contractor from earning a windfall, albeit capped, at the taxpayers’ expense. When considering this strategy against the history of change on MnDOT projects, which could be upwards of 10%, \$7 million is but 3% of the total project cost. MnDOT argues that the taxpayers are well served by this provision, which essentially hedges the risk and reduces the extraordinary time spent in managing the change process, freeing up staff for other projects.<sup>3</sup>

The notion of a contractor windfall (and the subsequent objections from the taxpayer’s perspective) for this type of no-excuse bonus is hard to “prove” if the contractor is permitted to keep claims close to the vest until the end of the job, as in a fixed-bid proposal versus a construction management at risk delivery. One possible solution to modify this no-excuse

---

<sup>1</sup> Ibid., Kaai.

<sup>2</sup> Mike Vogel and Paul Youngquist, presentation, October 29, 2008.

<sup>3</sup> Ward, MnROC 52 case study, previously cited. Ward subsequently commented that a number of changes were processed; however, when Flatiron agreed to accept the no-excuse bonus, then all claims were meant to be resolved at that point.

concept is to establish a threshold such that if the aggregate of claims falls within a certain range, such as 80% to 120% of the bonus, then the bonus would automatically be paid, with the 20% below the bonus attributable to the savings in administrating and potentially litigating the change for the owner, and the 20% above the bonus attributable to the common perception that contractors often do not get 100% of what they claim (recognizing that to do so would incur additional administrative and legal expense).<sup>1</sup> But in no case should a bonus of this type limit the ability of a contractor to make a claim.

The bottom line for agencies is this: Change is inevitable. Agencies need to plan for change and budget accordingly. No matter what the nature of the project, some form of change is possible, if not inevitable. When a project is more complex, there is greater potential for change, and it is a better prospect for best value procurement. And best value does not so much reduce the change order cost impact as establish a better process for managing the risk of change, since there is no guarantee that the lowest price will be the best value award.

### **Scope Management**

Definition: *Effect of best value on the owner's ability to manage program requirements*

The management of the project scope is entirely within the control of the owner/agency, and as such is *generally* unaffected by best value procurement. The reason is simply this: the owner/agency develops the project scope well before the request for proposal is tendered. Presumably, all the owner program issues have been addressed well before a contract is let.

This is sound in theory, but not always in practice. Our research has found that in many cases the owner/agencies were their own worst enemies when it came to change orders. As was mentioned under Change Management, one of the key areas of change is owner-directed change. In fact, the University of Minnesota has identified itself as its largest source of change.<sup>2</sup> Theoretically, if the owner wants to change something, so what? It is the owner's project, after all. But the industry recognizes that change is highly disruptive to the construction process, often resulting in cost increases and time delays. So in fact the management of the project scope is critical in maintaining budget and schedule. And there are two areas related to the scope management parameter that affect, or are affected by, best value.

First, a design-build delivery method executed under best value procurement can affect the project scope since the project criteria are usually identified in a broad, generalized manner rather than a narrow, specifically defined one. It is most imperative that the scope be as well identified as possible in the request for proposal, since the chance for a portion of the proposal to not meet an owner's objective is fairly high, resulting in either a change to the scope or a reduction in scope to meet budget. It is safe to suggest that design-build delivery will have the least impact on scope if the parameters of the desired design are well articulated, fairly simple, even routine. Though the project itself was not simple, the argument could be made that the I-35W Bridge scope was fairly simple—cross the river from point A to Point B with five lanes each way while maintaining the shipping lanes. The evaluation came down to a number of factors, including design, and not to the essential scope of the project. As was discussed earlier, the issue of the steel versus concrete design did play a significant role in the technical evaluation.<sup>3</sup>

---

<sup>1</sup> Modified bonus concept attributed to Dean Thomson.

<sup>2</sup> Kaai presentation, September 17, 2008, previously cited.

<sup>3</sup>See "Subjectivity vs. Objectivity" under the Qualifications section.

Second, the process of risk assessment during the pre-contract procurement phase can reveal programming flaws or incompatibilities, creating a change that could result in a bidding addendum prior to the award of the contract. This is especially true in a remodeling project, wherein a construction procedure or sequence identified during the risk assessment plan may actually cause a change to the owner's program. Consider the case of Roseville's Ice Arena project. Geothermal design requires a fairly precise length of well pipe to achieve targeted results. The soil borings revealed an average design length of pipe, but actual drilling revealed a somewhat less serviceable length, requiring additional pipe length and wells. The project planning anticipated that this potential condition might require more depth, but when additional depth was not available, more site area had to be dedicated to obtain the correct total pipe length. Though this had not been anticipated, a design solution was able to be quickly established.<sup>1</sup>

Scope management is generally not affected by best value, but the best value risk assessment component can help find weakness in the owner's programmatic scope.

### **Separation of Responsible Parties**

*Definition: Impact of best value on the separation of architect, owner, and contractor*

By and large, best value procurement is unaffected by the traditional separation of architect/owner/contractor. Since the delivery methods are also similarly unaffected, the same level of separation exists for standard procurement and best value. The primary concern is the maintenance of quality control and representation under dispute resolution. The owner/agency must still assume ultimate responsibility for the design under the design-bid-build delivery method, but retains the design entity under a direct contractual relationship to fully represent the owner (Figure 3).

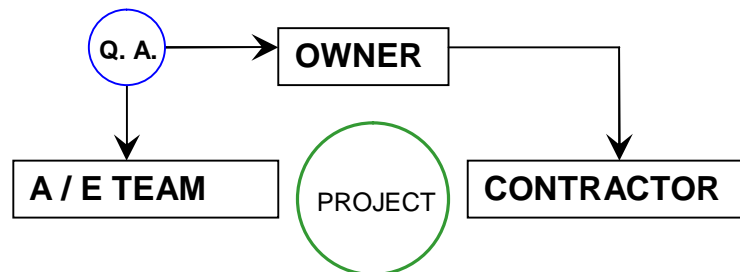

Figure 3: Traditional separation of parties and responsibility for quality assurance

In a design-build delivery method (Figure 4), the design entity and the contractor are on the same team, so the owner/agency must find other ways to have its interests represented. In the case of MnDOT, there is sufficient professional experience within its ranks to assume the oversight responsibility, but this is not the case with most agencies that carry out far fewer projects. There are two scenarios, however, where the owner/agency needs to concern itself with this traditional separation of responsibility.

<sup>1</sup> Loren Brokke and Jeff Evenson, City of Roseville, presentation, October 22, 2008.



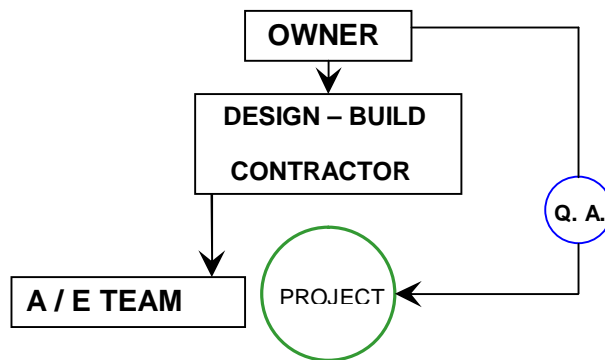

Figure 4. Design-build structure where separation of parties is not maintained and quality assurance requirements are either outsourced or managed in-house, as with MnDOT

The first is when multiple financing sources are incorporated, usually the result of private/public partnerships. The case of the Twins stadium is an excellent example of this. Of the \$521 million total construction cost, \$350 million was the capped public investment, representing nearly 60% of the financing. The Twins were responsible for the balance of the budget, including all cost overruns. So even though the Twins had a lesser overall investment, they had all the project cost risk, and therefore had to maintain control over design and procurement. The public sector, in the name of the Ballpark Authority, still had a vested interest in its funds being wisely spent and maintenance of the quality of the project. Its representation in the process was through a dedicated construction management consultant with large project and stadium experience to oversee all aspects of the design, procurement, construction, and quality control and have the authority to reject any unfavorable circumstances or conditions (Figure 5).<sup>1</sup>

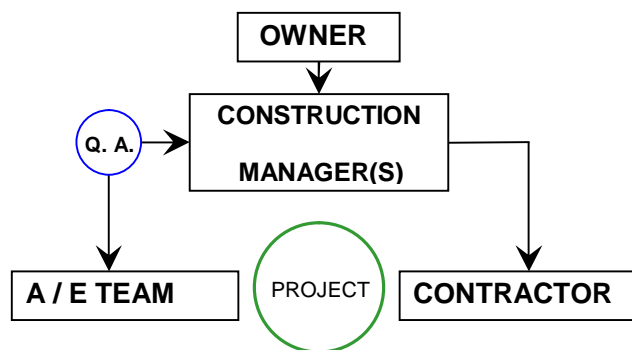

Figure 5. Construction manager's approach used for several agencies where separation of parties and quality assurance is maintained; used for the quasi-public projects

The second scenario relates to the use of alternative technical concepts, frequently a hallmark in best value procurement. This process, discussed earlier, permits a contractor to suggest, under certain circumstances, another way of doing a part of the project that is technically different from what the design drawings or specifications suggest, but results in at least the same performance outcome. The theory is that the contractor can sometimes find cheaper or better ways of accomplishing a component than the design suggests. The risk for the owner/agency in this scenario is the *acceptance of liability* for this alternative technical concept.

<sup>1</sup> Mr. Ed Hunter, Ballpark Authority, presentation, November 12, 2008.

Does the liability for this modified design remain with the contractor? Does the owner/agency, by virtue of its technical acceptance, also accept the design liability? By way of example, if a Gabion retaining wall system is proposed in lieu of a poured-in-place concrete retaining wall system, and the Gabion wall fails in some respect, does the contractor that presented it, or the owner that accepted it, retain the liability for the failure? That is a tough question that, if not managed properly, will only get answered in court, and gets to the root of this separation of responsible party parameter.

MnDOT has extensive experience with this process and, because of its internal expertise, has the ability to accept a higher level of risk. However, for an agency with less internal technical experience, the reliance on the design professionals to evaluate the alternate concepts, and all the supporting engineering that must accompany the proposal, is critical. The owner/agency ultimately absorbs the risks of the project with those that cannot be delegated out to others. In this scenario, the review of the submitted information in support of the alternate technical concept, and the owner/agency acceptance of that information, *potentially* puts at least a portion of the liability on the agency (except if the information supplied in support of the alternate technical concept is found to be negligent or in some manner deficient.) Every agency is urged to seek out qualified legal opinions on the question in the event alternate technical concepts are used.

One final note relative to this separation parameter is the use of “performance” rather than “standard” prescriptive technical specifications. By specifying the performance result of an assembly rather than the specific means and materials for constructing the assembly, the owner retains responsibility that the performance standards have been properly described and can be measured in some manner. In the absence of such description, the range available for an “acceptable” result is much wider than the owner/agency may truly wish to accept. It is important for the owner/agency to ascertain that the performance criteria are well written and measurable, and this evaluation may require consultative assistance.

## **THE CONTRACTOR'S PERSPECTIVE**

Though the owner's perspective, not the contractor's, was the focus of this study, the few contractors interviewed were quick to offer opinions.<sup>1</sup> Contractors are born to build, not to write. One of the most persistent, though cautious, complaints registered by the few contractors interviewed was the dependence on the written word rather than on the price. The evaluation of contractors in a best value process is dependent on the commentary of others to measure experience and also the narrative description of the project risks that form the basis of risk assessment tools. This is simply new territory, requiring the contractor to verbalize the risks that, as an entity, it intuitively knows so well. Small contractors without a marketing department feel this puts them at a competitive disadvantage, even though they may have fitting experience and price.

What is unique to best value over lowest responsive, responsible bidder is the emphasis on risk assessment, which cannot be easily quantified, if at all. Risk assessment forces the "what if" questions to be asked and answered. These are not generally put into numbers, except under an "if discovered, then . . ." scenario. So clearly, what contractors have always understood to be the risk of the job, as reflected in the price and not described, must now be described, evaluated, and measured. This is not a bad thing, but the advice to an agency evaluating a written risk assessment plan is to search for the underlying understanding of the risk in the words presented by the contractor, not how well it was described. The identification of the project risks is a huge benefit that can avoid significant problems and cost overruns for both the owner and the contractor and is worth the effort, even if the writing is not exceptional.

Under the University of Minnesota's PIPS program, a common perception was that the experience scoring was dependent on the amount of similar projects a contractor could demonstrate—the more the better. This puts small, well-qualified contractors in a position of not being able to "get their foot in the door" at a public institution, whereas under the lowest responsive, responsible bid scenario, they merely have to submit their bond to prove their worth, even if their actual experience is not an exact match for the demands of the project. This perception probably arises out of inexperience and doubt about the University PIPS program, which requires from 1 to 25 surveys (past performance information—PPI) from previous clients and does not measure whether the project is "similar"—it merely measures key performance indicators on any project. The PPI is worth only 15% of the total weighting. It is useful to note that contractors routinely (and understandably) obtain references from only their best clients or most successful projects, which the PPI effectively measures.

A further contractor concern with the PIPS system is the requirement to assume all other risk assessment plans into the proposal "without additional compensation" if the contractor are to be selected for the project. The PIPS system will score a contractor under a prescribed formula and require that a risk assessment plan (RAVA) be developed. Prior to award (filter 4), the best-scoring contractor must review and acknowledge coverage of all the risks identified by the competing contractors, without modification of the price. Upon closer examination of the process, the University of Minnesota does not require a contractor to accept the project if the

---

<sup>1</sup> Author's note: The contractor's perspective of best value is worthy of further study, especially after more projects have been completed, to assess contractor profitability and process. Many contractors commenting specifically on the PIPS program did so carefully, so as not to jeopardize their standing within the program, which suggests there are perception issues, whether correct or incorrect, that perhaps need to be addressed.

contractor cannot manage, or has not accounted for, the risks of the project presented in other proposals. Accepting all the other risks is the contractor's choice. It should be noted that the *evaluation* of risk, such as through the PIPS process, is at the heart of making a best value determination. The option, therefore, to "bow out" and not jeopardize a contractor's potential for profit is advantageous to both parties.

Acceptance of other contractor's risks was not as much a factor on the Roseville Ice Rink, also awarded under the PIPS system, since there was such a small pool of contractors and the refrigeration system was fairly unique. Understandably, the modification of price would alter formulas and cause a more protracted process of award, not to mention a possible ethical problem. On the Minnesota Twins stadium, a more loosely structured best value procurement system was used for subcontractor awards, wherein the risks were reviewed with the best value subcontractor and the subcontractor was given the option to adjust its price if a risk was uncovered in the bid. The project management team then would make a determination whether the additional cost was fair and reasonable or whether negotiations needed to be opened with the next qualified bidder.<sup>1</sup> In fact, this methodology closely mirrors common practice in the private sector, likely an influence on this partially public, partially privately financed venture.

To its credit, the University of Minnesota has demonstrated through statistical evaluation a significant reduction of change orders (other than from its own directives or hidden conditions) and has indications in general contractor satisfaction surveys regarding profitability, with more than half the awarded contracts given to the best-qualified contractor that also had the lowest price. So it appears that those contractors familiar with the system do indeed do well financially, and that many of the contractor perceptions identified above might possibly be the result of not winning proposals under the PIPS system, for any number of legitimate reasons.<sup>2</sup>

One of the major concerns of contractors as a whole on any best value assessment is the treatment of change order history when evaluating experience as a qualification filter, regardless of the agency. Notwithstanding the best value system, contractors feel unfairly treated when the change order history, coupled with the schedule history, cannot be properly represented. This situation occurs when change orders are the result of owner directives or inadequacy, or errors or omissions on the plans over which the contractor has no control but is still required to report.<sup>3</sup> To an inexperienced agency, this report can put a negative spin on the contractor's experience if scored, since change orders always have a negative connotation in the public eye, however undeserved. This can be easily remedied by modifying a filter measuring change, reducing its weight, or possibly eliminating it altogether. After all, a properly structured risk assessment plan has a proven history of reducing post-award change orders. Such a plan is limited only to those changes that are truly unforeseen or directed as a scope change by the owner, thus rendering a contractor's change order history on other jobs less important.

---

<sup>1</sup> Mr. Ed Hunter, Ballpark Authority, presentation, November 12, 2008, previously cited.

<sup>2</sup> The University staff did confirm that owner-directed change orders and changes the result of hidden conditions do not count against a contractor's completed project evaluation, which is then used for future PPI scoring. Only issues that were under the contractor's direct control or within its RAVA plan that result in a change order would count against the contractor in future assessments.

<sup>3</sup> See Thomson, et al., page 48: When considering past performance, the contracting agency cannot consider a proposer's claims history, presumably the result of change orders.

It is reasonable to expect that a “new” system, fundamentally different from methods contractors have long been trained to use, will raise commentary, questions, concerns, and even doubt. Contractors may even avoid “bidding” a best value project, if for no other reason than the greater time commitment involved in preparing all the elements of a best value proposal. But there is also excellent evidence that the best value process, properly executed with solid technical and risk assessment components, benefits both the contractor and the owner. After all, for once the contractors cannot complain that a project was awarded to the low-bid contractor that probably made the biggest mistake! Consider the opinion of Patrick Harty, the president of Harty Mechanical, contractors for the Roseville Geothermal project: “We were partners on the project. And we needed to get it done so that they [the City] were happy and we were happy. It’s a good process and a great value for the City and for the contractors.”<sup>1</sup>



State of Minnesota – Transportation Building under construction  
(Photo by the author, September 2009)

---

<sup>1</sup> Patrick Harty, Harty Mechanical, interview, November 6, 2008.

## **PUBLIC PERCEPTION OF BEST VALUE**

For many years, the concept of best value procurement existed in relative obscurity, with even a majority of contractors only vaguely familiar with the alternative means of hiring contractors for public projects. The greatest publicity surrounded the award of the light rail system in Minneapolis, which is managed by MnDOT. Quietly, though still very much available to the public, MnDOT developed and refined the system of best value using a design-build approach, starting with the MnROC 52 project in Rochester. Faced with significant challenges involving the public affected by the prospect of eleven years of disruption, MnDOT carefully crafted a public relations initiative to describe how the process would reduce the time period to no more than five years. Road user costs were determined to be \$50,000 per day, so the reduction in time is economically significant. In fact, the contractor completed two years earlier than allowed, further saving upwards of \$36 million in road user costs.<sup>1</sup> As it is likely that only the affected public heard the message, the project was quietly and effectively delivered.

On August 1, 2007, the collapse of the I-35W Bridge changed all that, putting the pressure of a speedy reconstruction process under intense public scrutiny. The newspapers were filled with commentary on the process, much of it incredulous that the non-local contractor with the highest bid got the job. Other commentary targeted the weighting of the scores that seemed to favor public relations—something many had not even considered at all. Yet the decision to award was quickly consummated, and construction began immediately. In part because of its location, but also the proximity of the bridge reconstruction to the very accessible and adjacent Cedar Avenue Bridge, the entire project was in the limelight from start to finish. The public relations initiative, the target of earlier commentary, was playing itself out in the weekly “Sidewalk Superintendent Talks” held by Peter Sanderson, the project manager, or his staff, for the benefit of whoever would show up, which at times could number a hundred or more people. Project signs along the Cedar Avenue Bridge informed the nearly constant streams of onlookers, and an active Web site indicated steady and rapid progress.<sup>2</sup>

The bridge was completed in an astonishingly short time (with an attendant bonus for the contractor), and with the completion, the earlier criticism on the process appeared to evaporate from the media, replaced by widespread praise. So what happened?

One of the hallmarks of best value is that it quantifies risk by spending greater effort on the pre-award planning to deliver projects in a way that manages and meets, or even exceeds, the expectations of the client. This was certainly the case for the bridge, but was consistently reflected in the other projects examined as well. The client satisfaction rate is substantially higher at the University of Minnesota.<sup>3</sup> The problems at the South Washington County high school are minimal and very manageable, considering the size of the project and the propensity for school projects to be ripe for problems.<sup>4</sup> The Roseville Ice Arena project could have been a disaster with an inexperienced but qualified contractor, but instead was completed on time—the most critical expectation of the client. And when these projects go well, the public perception is effectively neutralized, since it is usually the problem projects that garner the greatest attention and criticism.

---

<sup>1</sup> Ward, MnROC 52 case study, previously cited, and subsequent clarification.

<sup>2</sup> Ibid., Ward.

<sup>3</sup> Kaai presentation, previously cited.

<sup>4</sup> Vogel and Youngquist presentation, previously cited.

Consider the ill-fated Wakota Bridge reconstruction—a project that has been mired in problems, extensively delayed, and is still not complete, creating a public relations nightmare for MnDOT. The rallying cry in the press was that if the I-35W Bridge could be completed so quickly, why can't the Wakota Bridge? The differences are significant. The Wakota was performed under a traditional design-bid-build delivery method, with major design errors causing MnDOT to suspend the project in search of funds rather than accepting the contractor's price to repair. The project was re-bid at a higher price than the original contractor had offered, and won by the original contractor.

Project disasters fill the media; project successes often go unnoticed. The challenge for agencies will be to maintain an appropriate level of public relations when initiating a best value approach. The concept that the best price is not always the lowest price can be a tough pill to swallow for a constituency entrenched in low-bid thinking for their taxpayer dollars. Yet on an individual level, the wide-ranging analogy that a consumer would often spend a bit more to get a better product is well known.

## **TRAINING**

The 2007 best value law clearly requires that any entity using this process be “trained.” Yet the specifics of what constitutes training, i.e. how many contact hours, content, etc., are not given. Constituting an unfunded mandate, the law provides no resources for agencies to achieve a level of training. Due to the relatively recent passage of the law, it is reasonable to presume that public agencies are still “testing the waters” on best value and taking a go-slow approach. But it is also reasonable to assume that the training mandate, given the scarcity and high cost of the training options, is a barrier to implementing a best value procurement program, especially for smaller public agencies that have limited resources and do not perform multiple annual projects.

The options for active, regular training are very limited. Arizona State University and its Performance Based Studies Research Group (PBSRG) is the only active, consistent program offering five-level training, varying in cost from a \$1,500 Level I basic informational training to upwards of \$115,000 for Level IV complete program implementation training. The basic Level II certified training is \$5,000 and requires 14 weeks. Other programs, mostly informational, have been held but would likely not constitute training under the law. One criticism of the ASU program, though not directly substantiated, is the high failure rate among participants taking the certification tests. In Minnesota, however, achieving a training standard for statutory compliance is not dependent on taking the certification tests.<sup>1</sup>

The University of Minnesota has been fully trained in the program and uses ASU for its projects. Of the other agencies examined, only the City of Roseville participated in an active training program, also at ASU. MnDOT was not required to “train” under its design-build enabling legislation and basically developed its own program from scratch. The Ballpark Authority’s enabling legislation did not require training. SoWashCo School District and Regions Hospital did not use best value and therefore were not required to train. The Minnesota Department of Administration did not engage in any formal training and established its own program. Interestingly, it has the authority to set appropriate training requirements.

There is little doubt that training is a good thing. Best value has significant potential for a legal challenge if not handled properly, and training can certainly assure that the hallmark concepts of best value—risk management, experience, transparency, and neutrality—are appropriately planned and managed. In the absence of a definition on training under the law, it is conceivable that the courts may unwittingly decide what constitutes an appropriate level of training. Without taking away from the successful and rigorous PBSRG program at ASU, an opportunity exists for the development of a regional, Minnesota-based training program that meets the intent of the law and, more importantly, is affordable and accessible to the county, city, and local government units that the 2007 law was intended to benefit.

---

<sup>1</sup> Both Evenson and Thomson reported taking the test, but also reported being told the failure rate is as high as 66%.



## **LESSONS LEARNED: SIX BEST PRACTICES**

Best value is fundamentally grounded in minimizing project risk, where such risk is consistently manifested in cost overruns, time delays, and lack of qualification of the contractor to perform the work. The private sector has long recognized the free-roaming ability to contract with the firm most able to deliver on the owner's needs, be it cost, quality, or time, without the necessity of tight bidding rules. But both the private sector and the public sector have had success with both lowest responsive, responsible bidder and best value approaches, and there have been notable disasters as well. So what can we learn from the successes and the failures that can be applied universally, to public or private?

### **Project Planning**

The first and foremost lesson is that there is a need for appropriate project planning. Best value has shown that a pre-award assessment of project plans—better defined as the “work plans”—is the most significant tool in planning for and mitigating project risk. While this is essentially a requirement of best value procurement, there is nothing preventing the same rigorous analysis from being applied to any public project, regardless of whether it is best value or traditional lowest responsive, responsible bidder. The difference is that the typical design teams prepare the plans without the type of knowledge that contractors bring to the process. Perhaps it is time to bring more experienced construction management consultants to the planning process, regardless of procurement, to better assess the project plans, especially within those government agencies that lack the volume of project construction experience.

### **Transparency and Fairness**

If best value is used for public procurement, transparency of the process is paramount in achieving a fair result. The laws have somewhat loose guides for establishing procedures, but they must be more rigorously established and imposed on the process to assure fairness. The use of oversight committees, experienced personnel on the technical review panels, and legal guidance during the course of preparation and evaluation is important to achieving fairness.

One of the principal criticisms of MnDOT in the reconstruction of the I-35W Bridge was not for the lack of organization of the process, but rather for the lack of disclosure of the results prior to the award of the contract. This begs the question: if the process is indeed fair and open, would the result really change if the public, or at least the other proposers, is permitted to see the results prior to award? Theoretically, the result would not change if it was held to the scrutiny of the public eye that found the process to be fair. In the case of public design-bid-build awards, the results are read publicly prior to award. Indeed, some agencies, such as Roseville, did attempt to disclose the results of their best value award prior to contracting. And in the case of MnDOT, while numerous state and federal agencies did sign off on the process and the award to indicate that the procedures were correctly followed, it was done without the benefit of knowledge of the conditions underwriting the protest. So the message is, establish procedures that promote a fair and open process, advertise those procedures in the request for proposal, and make sure those procedures are strictly adhered to. Consider giving the public a brief period to review the scoring and the process prior to contracting to ensure the process is fair.

## **Filters Clarify**

The 2007 law is clear only to the extent that best value must use certain criteria—filters—to determine the best value. How those filters are determined and weighted in the formula is up to the agency, and correctly so. But to maintain a semblance of fairness, price must have an appropriate weight relative to all the other filters. Further, much of the evaluation of filters is subjective in nature. The advice to agencies is to make the evaluation of filters as quantitative as possible, with as little room for subjective interpretation as possible.

## **When Is Best Value Appropriate?**

Much of what is contracted is fairly routine, with a normal level of risk and reasonably consistent, manageable outcomes. What this study suggests is that the more complex a project, the greater the potential for best value. Project complexity is directly related to the level of risk. The more unusual the project, the greater risk to the owner that the project will experience significant problems, especially if poorly conceived or planned. Where certain factors exist, such as schedule, owner occupancy during construction, or other strategic sensitivities that need to be considered more than cost, best value will, when properly planned, determine the contractor best able to successfully manage those unique challenges. For these types of projects, the presence of contractors evaluating the risks prior to award, such as with the RAVA planning technique, provides important perspective on the process of construction that does not always result from the traditional planning processes.

## **Consider Your Overhead**

Best value as a process is more time-consuming for the agencies to establish and administer, at least for the first few projects. This will be a drag on internal productivity initially, but over time, as the process becomes more finely tuned, the benefits will mount. Indeed, it is conceivable that the savings in the traditional change order rate of best value over low bid may not support the added staff costs to establish the best value procedure, especially for the first project, and considering the cost of outsourced training required by the law.

## **Tap the Best People**

Best value is not a “slam dunk”—it does not “just happen if you jump high enough.” Many agencies simply do not have the technical expertise to create appropriate best value proposals, much less establish the right filters and measure the results correctly. It is especially important that the technical aspects of the project are reviewed by technically competent staff, even if they are not part of the agency. Retaining outside expertise to evaluate technical proposals also helps to validate the unbiased transparency of the process.

Best value is here to stay, and though it is not yet widely used, it is conceivable that a process properly defined, implemented, and observed can yield excellent results for the agencies and the taxpayers they serve.

## ACKNOWLEDGEMENTS

The authors wish to acknowledge the following student research teams, their agency representatives, and other participants and reviewers, for their time, energy, and contributions to this research initiative:

### LEGAL TEAM

Ms. Kelly Hoffman, student team  
Mr. Jay Isenberg, AIA, faculty adviser and legal roundtable moderator  
Mr. Jeff Wieland, Fabyanske, Westra, Hart and Thomson, PA  
Mr. Tom Vollbrecht, Faegre & Benson  
Mr. Richard Varco, Office of the Minnesota Attorney General  
Rep. Debra Hilstrom, Minnesota House of Representatives, sponsor, 2007 best value legislation

### MINNESOTA DEPARTMENT OF ADMINISTRATION

Mr. Adam Strack, student team  
Mr. Michael Meisinger, student team  
Mr. Gordon Christofferson, Department of Administration, Real Estate and Construction Services  
Mr. Wayne Waslaski, Department of Administration, Real Estate and Construction Services  
Ms. Brenda Thielen Willard, Department of Administration, acquisitions manager

### MINNESOTA DEPARTMENT OF TRANSPORTATION

Mr. Sean Rivard, student team  
Mr. Thomas J. Hinz, student team  
Mr. Terry Ward, Minnesota Department of Transportation, deputy project manager, I-35W  
Mr. John Chiglo, Minnesota Department of Transportation, project manager, I-35W  
Mr. Jay Hietpas, Minnesota Department of Transportation, project office manager, I-35W  
Mr. Kevin Gutknecht, Minnesota Department of Transportation, communications manager

### UNIVERSITY OF MINNESOTA

Mr. Tyler Safratowich, student team  
Mr. Daniel Spa, student team  
Ms. Nacole Kaai, University of Minnesota, Capital Planning and Project Management  
Mr. John Savicky, University of Arizona, Performance Based Studies Research Group

### CITIES AND COUNTIES

Mr. Michael Michelsen, student team  
Mr. Randy Faasuamalie, student team  
Mr. Lonnie Brokke, City of Roseville, director of parks and recreation  
Mr. Jeff Evenson, City of Roseville, park planner  
Mr. Duane Schwartz, City of Roseville, public works director  
Mr. Patrick Harty, Harty Mechanical, president  
Mr. Russ Matthys, City of Eagan, city engineer  
Mr. John Gorder, City of Eagan, assistant city engineer  
Ms. Susan Nemitz, director, Ramsey County Library

### REGIONS HOSPITAL

Mr. Ross Hoeffner, student team  
Mr. Will Schultek, student team  
Ms. Barbara Reichter, facility planning director  
Ms. Linda McCracken-Hunt, Studio Five Architects, owner's representative

## **HENNEPIN COUNTY BALLPARK AUTHORITY / TWINS STADIUM**

Mr. Adam Bakeman, student team  
Ms. Angie Myrechuck, student team  
Mr. Ed Hunter, Ballpark Authority representative  
Mr. Dan Mehls, Mortenson Construction, project manager  
Mr. Dick Strassburg, Minnesota Twins, owner's representative

## **SOUTH WASHINGTON COUNTY SCHOOL DISTRICT**

Mr. Kris Hahn, student team  
Ms. Krystal Kurn, student team  
Mr. Mike Vogel, SoWashCo School District, assistant superintendent for operations  
Mr. John Huenink, Kraus-Anderson Construction, vice president  
Mr. Paul Youngquist, Rego & Youngquist Architects, architect  
Mr. Bob Meeks, Minnesota School Boards Association, executive director

## **PRIVATE SECTOR AND PUBLIC PERCEPTION**

Mr. Marc Stauffer, student team  
Mr. David Meyers, student team  
Ms. Teresa Sterns, Sterns and Associates, president  
Mr. David Bergstrom, Wellington Management, director of project management & construction services

## **TRAINING**

Mr. Mark Drewiske, student team  
Mr. Jeff Evenson, City of Roseville, park planner  
Ms. Sylvia Romero, Arizona State University

## **AT LARGE**

Mr. John R. Goeckel, PE, guest speaker, owner's representative  
Ms. Linda Clemens, University of Minnesota Center for Writing

## **GENERAL REVIEW**

Mr. Dean Thomson, Fabyanske, Westra, Hart and Thomson  
Mr. Robert Sands, PE, Jacobs Engineering Group

Ms. Kelly Hoffman, student team

### **Design/Build Law and Prior**

Before either the 2007 best value or the 2001 design-build legislation was enacted, most public construction contracts were awarded based on the lowest responsive, responsible bidder approach. Within this original system, Uniform Municipal Contracting Law (UMCL), all public and state agencies were required to conform to sealed bidding when letting a project exceeding \$50,000 and award said project to the lowest responsible bidder.

It was not until 2001 that a public agency could use anything relating to best value when awarding contracts. Within this new legislation, MnDOT was allowed to “solicit and award a design-build contract for a project on the basis of a best value selection process” (161.3412 subdiv.1) if adhering to regulated conditions. These conditions included a “two-step competitive process” (161.3412 subdiv. 2).

The first step involves the appointment of at least five members to serve as a technical review committee (161.3420 subdiv. 2). MnDOT then needs to prepare a request for qualifications, including the following:

- Minimum qualifications of the bidders
- Statement of work
- Schedule
- Project requirements
- Weighted criteria for selection
- Form of contract to be awarded
- Number of firms to be selected for the short list
- Description of the request for proposal requirements
- Maximum time allowed for the project
- MnDOT’s estimated cost of the project
- Requirements for resources and experience

Depending on the number of teams that respond, between two and five will be selected for the “short list,” and they will proceed to the second step. In the second step, MnDOT issues a request for proposal to each of the above-mentioned short-listed teams. The RFP must include the following:

- Statement of work
- Description of the required qualifications
- Weighted selection criteria
- Copies of the contract that the winning proposer will be expected to sign
- Maximum time allowed for the project
- Estimated cost of design and construction

The technical review committee will review the proposals, reject any considered non-responsive, and submit the scores for those that are responsive. The technical scores are announced at bid opening, followed by the opening of the price proposals. Each bidder’s price will be divided by its technical score, and unless MnDOT’s commissioner uses his discretion to reject all the proposals, the builder with the lowest adjusted score wins the project.

## University of Minnesota Law

In 2005 the University of Minnesota, along with the Minnesota Department of Administration and MnSCU, was given authority to use design-build contracting. The two authorized types of design-build procurement are qualifications based selections (QBS) and design-price based selection (DPBS).

The QBS process starts with an agency-issued RFQ that lists the weighted criteria that will be used to evaluate the proposals. The criteria referenced in the law must include the following:

. . .the proposer's experience as a constructor, designer or design-builder, its key personnel, its technical competence, its past performance on similar projects, its safety record and its availability and familiarity with project locale.

The RFQ may also ask the proposed overhead and fees portion of the proposal to reiterate that cost is still an issue, not just quality. The designer selection board will create a short list of at least three, but no more than five, proposers. Proposals and formal interviews from the short-listed proposers will be scored based on the established evaluation criteria, and the top two scorers will be recommended by the designer selection board to the University Board of Regents, who will make the final decision.

The DPBS requires a two-step process involving an RFQ followed by an RFP from the short-listed competitors. Included in the RFP are "preliminary plans and specifications, a critical path method schedule, and a guaranteed maximum price for the project" (Id subdiv. 7(c)). The state designer selection board will evaluate the proposals based on the evaluation criteria, and the commissioner must award the contract to the bidder with the highest score.

## 2007 Best Value Legislation

The success of the University of Minnesota's PIPS program had a significant role in the development of the best value legislation. The University experienced a 13% savings using the best value system, and because of its success, the writers of the legislation used the PIPS program as a basis for the development of their own system. The University testified before every committee, sharing the story behind its program. Two criteria taken into consideration with the PIPS program are past performance and minimizing risk. Coincidentally, while using this system, the University of Minnesota has awarded approximately half of its contracts to the lowest bidder.

The new legislation has been implemented gradually by allowing only 20% of an organization's projects to be contracted in each of the first three years. Further, only state agencies, counties, cities, and the largest 25% of school districts could use it in the first two years following the legislation's enactment. After the first two years, the largest 50% of school districts and political subdivisions have been allowed to use it, and then it will finally become unrestricted after three years.

The best value legislation allows state and local governments to consider using best value contracting as an alternative to the current low-bid system. This form of contracting considers both performance and price. The purpose of having this alternative to the low-bid system is to reduce risk by considering contractor performance instead of just low bid. Because the use of best value contracting is optional, it does not replace or alter the current low-bid system.

The benefits of this system will reach taxpayers by determining the best overall value, state and local governments through the increased options in contracting systems, contractors by rewarding skill and encouraging training, and finally, businesses by maximizing quality and minimizing risk.

Because this legislation is so new, there has been no substantial feedback from users, positive or negative. It is too soon to tell if any changes will need to be made to the legislation, but one issue has been brought up repeatedly throughout this research process: the training requirement. While there was positive feedback on the training requirement during the legislative writing process, it has been a topic of controversy within this course. According to the legislation, “any personnel administering procurement procedures for a user of Best Value Procurement or any consultant retained by a local unit of government to prepare or evaluate solicitation documents must be trained, either by the department or through other training, in the request for proposals process for Best Value contracting for construction projects.” The issues surrounding this requirement are availability of training programs and their cost. (See Training section in this paper.)

### **Twins Legislation**

The Minnesota Twins stadium legislation was approved on May 21, 2006, based on public funds of \$260 million and a required \$130 million contribution from the Twins along with any cost overruns. The breakdown of the public contribution included \$90 million for infrastructure and \$260 million for the actual ballpark. In addition to the \$130 million contribution and responsibility for cost overruns, the Twins signed a 30-year lease, ensuring long-term use of the facility for its original purpose as a major league baseball stadium.

Contracts for labor, materials, supplies, and equipment will be awarded based on the process of public bidding unless the construction manager receives approval from the authority or the team regarding the following items listed in the legislation (section 9.15-9.22):

1. Narrow the list of bidders to those which the construction manager determines possess sufficient expertise to perform the intended functions.
2. Award contracts to contractors the construction manager determines provide the best value, not required to be the lowest responsible bidder.
3. For work the construction manager determines to be critical to the completion schedule, award contracts on the basis of competitive proposals or perform work with its own forces without soliciting competitive bids if the construction manager provides evidence of competitive pricing.

### **I-35W Legal Challenge**

In October 2007, after the contract for reconstruction of the I-35W Bridge was awarded to Flatiron, a civil suit was filed against MnDOT by Scott Sayer and Tony Phillippi on behalf of the Minnesota taxpayers. The intent of the original suit was to void Flatiron’s contract and require MnDOT to re-bid the project. It alleged that Flatiron’s proposal should have been eliminated by the review committee, based on several factors. These issues included:

- The bridge design failed to meet MnDOT’s specifications.
- Portions of the design were outside the right-of-way restrictions.
- Project requirements were ambiguous.
- The scoring system was arbitrary and capricious.

Flatiron's brief in response to the suit claimed that "these assertions were unsupported and demonstrably false," declaring:

- Flatiron's concrete box design had more than the required three webs.
- The proposal to vertically lower the street's profile was within the right-of-way boundaries.
- The proposal addressed and fulfilled MnDOT's request for vertical profile enhancements, unlike the losing bidders' proposals.

Flatiron requested that the court deny the plaintiff's motion for a temporary restraining order. Motion for the temporary restraining order was denied on October 31, 2007.

The law covering this case is MnDOT's design-build law, which was outlined under the history of best value procurement earlier in this appendix. The 2007 best value legislation does not apply to the 35W Bridge contract. The 2007 best value legislation allows local governments to use best value criteria to award bids, while MnDOT's legislation allows them to quickly bid projects using a one-step process versus their regular two-step process, if time is a critical factor.

#### **SOURCES:**

Representative Debra Hilstrom: interview, handouts, guest lecture.

Best value legislation on public Web sites.

Legal roundtable held October 1, 2008 at the University of Minnesota, including Mr. Jeff Wieland, Fabyanske, Westra, Hart and Thomson, PA, representing the plaintiffs; Mr. Tom Vollbrecht, Faegre and Benson, representing Flatiron/Manson; and Mr. Richard Varco, attorney with the Minnesota attorney general's office, representing MnDOT.

*William Mitchell Law Review.*

Twins stadium Web site and guest lectures.

Legislation on Web site.



Mr. Adam Strack and Mr. Michael Meisinger, student team

## Introduction

Real Estate and Construction Services (RECS) provides a broad range of services including pre-planning, acquisition, disposition, leasing, project management, relocation, and space management services to facilitate solutions that help Minnesota state agencies succeed. Minnesota state agencies and services occupy a total of 29 million square feet in more than 5,000 buildings. The Construction Services Section is the state's owner's representative on construction projects for a diverse collection of state-owned buildings, including the Minnesota State Retirement System occupying one building containing 146,500 square feet, the Department of Corrections with 283 buildings and more than 5,592,818 square feet, and the Department of Human Services with 192 buildings and more than 3,000,000 square feet. The property types include office space, storage/warehouse space, workforce centers, residential facilities, hospitals, training centers, correctional facilities, environmental monitoring sites, boat slips, laboratories, driver vehicle exam stations, communication facilities, probation offices, and licensing centers.<sup>1</sup>

The Minnesota Department of Administration is currently in the process of contracting its first best value project. The project is the Minnesota Transportation Building exterior granite façade repair on the St. Paul Capitol campus. The 380,000 square foot building was built in 1959. Due to the deteriorating exterior granite panels, approximately \$800,000 in temporary fall protection was installed until full funding could be approved by legislation. In 2008, legislation was approved to fund \$18 million for design and construction. The project scope includes replacing select exterior panels, repairing the structural support system, and restoring the I-beams of the west curtain wall. A design bid-build delivery method is being used; a full set of drawings and specifications were available for contractors to review while preparing their proposals. Notice to proceed (NTP) was issued October 24, 2008. Contract completion time is 447 days from NTP = Jan 14, 2010.<sup>2</sup>

First exposure to best value concepts began with a one-time legislative authority in 1997 to use the design-build delivery method. Until then, the lowest responsive, responsible bidder method was used to procure all construction projects. The 1997 authority marks the first time factors other than price were used to determine the winning bidder. The 1997 design-build authority was given by the legislature with the funding for a specific project due to its difficult schedule constraints. In 1999 RECS was again given the ability as a result of one-time limited legislation to use design-build for a specific project. This marks the second time RECS was granted the ability to evaluate contractors based on criteria other than price. Both projects were viewed as successful and gave RECS the experience using design-build for state agency facilities.

---

<sup>1</sup> Minnesota Department of Administration, Real Estate and Construction Services (RECS) Web site. November 2, 2008. <http://www.admin.state.mn.us/recs/index.html>

<sup>2</sup> Gordon Christofferson and Wayne Waslaski, Department of Administration, Real Estate and Construction Services, best value construction procurement presentation, October 15, 2008.

In 2002, another round of limited legislation was passed, giving RECS the option to use design-build; this legislation was set to expire at the start of 2004. During this time no projects were contracted using this method. Although the opportunity to use design-build was available, RECS did not identify any projects as potential design-build candidates during this time.

In 2005, Minnesota Statutes 16C.02 & 16C.32-.35 were introduced and gave RECS multiple methods for contracting construction services. This new legislation included additional methods outside the traditional low bid evaluation, such as design-build, construction manager at risk, and job order contracting. This legislation gave RECS general authority to use multiple delivery methods and further added to the success of early design-build projects.<sup>1</sup>

In 2007, new legislation made best value procurement a general authority option for RECS. The current project at the Minnesota Transportation Building is the first time RECS has used the best value authority outlined in Minnesota Statute 16C.02 Subdivision 4a.

It is important to note RECS has been using an RFP process for many years to evaluate designer selection. According to RECS representatives Wayne Waslaski and Gordon Christofferson, this process uses many of the same quality and performance criteria used to determine best value contractors. Due to the designer selection RFP process, RECS is experienced in evaluating proposals that include factors outside price.<sup>2</sup>

The basic project management structure for best value projects does not dramatically affect internal management for RECS. One full-time project manager within RECS is assigned to oversee the scope, schedule, and budget. This project manager will also interact and manage the design team when a design-bid-build delivery system is used, such as for the Minnesota Transportation Building project.

Another division within the Department of Administration is Materials Management. The Acquisitions section of the Materials Management Division (MMD) serves to support the commissioner of administration's statutory responsibilities (Minnesota Statutes Ch. 16C) in the open and competitive acquisition of construction services.<sup>3</sup> MMD is an important player in the best value contracting process. MMD is responsible for providing a single point of contact for contractor questions during the proposal process. MMD also serves as the outside authority to ensure all evaluation team members are educated to score proposals accurately. The RECS project manager and MMD-appointed contact work closely to ensure the proposal process is conducted according to the state guidelines. The role of MMD is to solicit the bidding documents for public bidding. The responsibility of preparing the bidding documents and managing the overall project is owned by RECS. Together RECS and MMD form the project management structure that makes best value contracting an accurate and viable option for Department of Administration construction projects.

---

<sup>1</sup> Gordon Christofferson and Wayne Waslaski, personal interview, October 1, 2008.

<sup>2</sup> Christofferson and Waslaski, best value presentation, October 15, 2008, previously cited.

<sup>3</sup> Minnesota Department of Administration, Materials Management Division Web site, November 2, 2008. <http://www.mmd.admin.state.mn.us/> Path: Construction.

Contracting with the lowest responsive, responsible bidder has been the standard for this agency for many years. Although the low-bid process appears to be simple and transparent, the Department of Administration has had good and bad experiences. Using BVP is intended to eliminate the low-performing low-bid contractor from repeat work. BVP allows the Department the ability to consider additional, and sometimes more important, criteria than price. In the case of the Transportation Building, BVP was used because of unique project needs/goals.

- The building is high profile, located on the state Capitol campus.
- The building will be occupied during construction, and state employees need to maintain their usual productivity at all times; construction cannot interfere.
- Safety for pedestrians and employees must be ensured.
- Schedule cannot be compromised by the inability of a contractor to manage labor and materials.<sup>1</sup>

Due to these factors, RECS believes using the best value authority will produce the most favorable results. Although lowest price is not listed as a specific project goal, RECS will use price as one of many selection criteria to contract with the highest performing contractor within legislative funding.

BVP is used when the critical goals/needs of the project include contractor experience, planning, scheduling, and risk management. Price is always a consideration when evaluating contractor proposals, but due to previous experiences with low-performing contractors, underbidding competition to ensure work BVP may become a viable option for RECS. To date, a specific process to determine when the critical goals/needs of the project define whether BVP will be used has not been established. At this time the experience and judgment of RECS project manager and upper management make the final determination if BVP is used. RECS does not intend to develop a standard set of criteria to determine when BVP is chosen for a project. RECS plans to continue using the experience and knowledge of its staff to determine if BVP is appropriate.<sup>2</sup> For the current Minnesota Transportation Building exterior facade repair project, RECS developed evaluation criteria using Minnesota Statute 16C.02 Subdivision 4a. It was determined the following criteria were the most important for finding a high-performing contractor for this project:<sup>3</sup>

- Abatement subcontractor experience
- Project approach and scheduling
- Prime contractor experience
- Prime & sub personnel experience
- Safety

BVP enables RECS to gain specific information for the five categories listed above to make its contractor selection.

---

<sup>1</sup> Christofferson and Waslaski, best value presentation, October 15, 2008, previously cited.

<sup>2</sup> Gordon Christofferson, construction program manager, Real Estate and Construction Services, Minnesota Department of Administration, personal interview, October 14, 2008.

<sup>3</sup> Minnesota Department of Administration, Real Estate & Construction Services RFP, Minnesota Transportation Building Exterior Façade Repair, revised August 5, 2008.

For RECS, the value of BVP is contained within the information and submittal requirements of the RFP. Contractors are scored according to criteria such as

- Project approach, work plan, and scheduling
- Contractor's and subcontractor's experience in comparable projects
- Staff experience in comparable projects
- Safety program and history or violations/OSHA record
- Price compared to their competitors<sup>1</sup>

BVP was used for the Minnesota Transportation Building because the building has a high profile location on the Minnesota Capitol campus, it will be occupied during construction, there are unique safety concerns because of existing façade conditions, and the contractor must complete the work according to specific schedule constraints.

In addition to evaluating projects based on critical needs/goals using BVP, the project manager is able to evaluate additional criteria such as experience. For the Minnesota Transportation Building, project experience was evaluated based on similar projects performed by the general contractor and major subcontractors. Each general contractor responding to the proposal was required to submit information on previous similar exterior envelope projects for occupied buildings. The size and scope of previous projects was also evaluated; for this project the general contractor had to have successfully completed three similar projects of \$1,000,000 or more within the last ten years. Customer references from similar projects are also required as part of a successful RFP submittal.<sup>2</sup>

RECS believes the information collected in the RFP is important because high-performing and experienced contractors will be better able to produce the required submittals and manage and administer the project general conditions. A low-performing, less-experienced contractor may have difficulty obtaining three favorable customer evaluations from previous projects. Also, a contractor with little experience on exterior envelope repair projects in an occupied building will score low on the RFP. Thus, the process seeks to remove low experience and low performers before a contract is executed.

An example of the success of BVP on the current project is section 2.0, Project Approach, Work Plan and Scheduling of the RFP. This section of the RFP requires the contractor to provide RECS with information on how the project work will be planned and delivered. In particular, the contractor must explain site coordination, its approach to managing the construction activities on an occupied building site, and its risk assessment and mitigation strategies. While reviewing proposals, it was found that one contractor proposed removing one section of the roof to access structural supports for repair. Although the contractor believed this could be done without causing disruption to building occupants, RECS did not agree. Other proposals were reviewed carefully, and only those work plans that RECS deemed not a disruption to building occupants continued to be scored. This is important to note because in a low-bid environment the contractor is not required to present its work plan prior to contracting.<sup>3</sup> If the contractor had

---

<sup>1</sup>Ibid., Minnesota Department of Administration RFP.

<sup>2</sup>Ibid.

<sup>3</sup>Christofferson and Waslaski, best value presentation, October 15, 2008, previously cited.

been awarded the contract, a major problem could have occurred because its work plan would have caused a disruption to building occupants. The contractor and RECS would have been forced to solve an important issue during construction rather than before construction had begun. This created a potential change order environment; thus BVP enabled RECS to mitigate the problem before it could occur.

The Minnesota Transportation Building project is the first BVP project for RECS. At the time of our research the contract had just been awarded and work had not begun. Due to this schedule we are not able to compare the change order rate for BVP projects vs. other procurement methods. RECS intends to track change order rates for BVP projects.

RECS is responsible for determining which procurement method and delivery method is used for each project. Candidates for BVP are selected on a case-by-case basis. The RECS project manager and management collaborate to determine the critical needs/goals for the project. Based on the critical needs/goals, BVP may be used. For example, BVP was used for the Minnesota Transportation Building because the building is high profile on the Capitol campus, the building will be occupied during construction, there are unique safety concerns because of existing façade conditions, and the contractor must complete working according to specific schedule constraints.<sup>1</sup>

### **Solicitation**

16C.02 Subd. 11 refers to a solicitation in which the terms, conditions, and specifications are described, and responses are not subject to negotiation. The RFB was created between RECS & MMD. Proposals are advertised through the state's (MMD) Web site. Online the state has a Web site for bidding state construction projects. Notices were sent to major builders' exchanges and plan rooms. There was no difference in their solicitation because of the use of BVP. There was also no stipend offered or provided to the bidders.

### **Qualification**

The qualifications are part of the RFB and are developed based on specific projects. "If responders or prospective responders can demonstrate in their response that they meet the criteria as published in the RFB, they are eligible to participate."<sup>2</sup> One of the qualifications represented in the RFB was safety. The state also needed the contractor to have proof it had done three similar projects per degree of scope in the last ten years. There is a boilerplate document with general conditions that act as a filter for contractors who are not able to meet the criteria to work on state projects. The goal is to create qualifications that are objective in the low responsive, responsible bidder. There are no pre-qualified lists, and the state does not anticipate creating such a list in the future. It is believed there is too high a potential for claims and challenges with the use of a pre-qualified list versus the qualification of bidders on a per-project basis.

---

<sup>1</sup> Ibid.

<sup>2</sup> Minnesota Department of Administration RFP, previously cited.

## Transparency and Neutrality

The RFB is publicly advertised on the state's Web site created for state projects and contains criteria for selection. There is an evaluation team, which attends an orientation meeting to discuss conflicts of interest, RFB and proposal information, questions during bidding, and the score breakdown. The evaluation team is told not to discuss the RFB and proposal information with anyone during the bidding period. Also, all questions asked by the public and bidders are directed toward one contact in MMD, so all information is received and distributed from the same source. The evaluation team grades the RFBs in a non-blind atmosphere. Price is then graded after evaluation and grading of qualifications. Unlike the University of Minnesota PIPS program, there are no evaluation tools during the construction phase. If the contractor is not performing per state expectations, the contractor is sent written notice that allows time to solve the problem, rather than rating the contractor lower for the next project.

## Delivery Method(s)

According to Gordon Christofferson, "The BVP process applied to the Transportation Building project was done under a design-bid-build method. RECS will apply BVP to design-build and construction manager at risk. The initial challenges are with the contracts that are used for each delivery method since design-build and construction manager at risk require their separate family of RFQs, RFPs, A&E and Contractor contracts.<sup>1</sup> RECS's plan is to match the project delivery method with the project needs. In 1997 RECS used design-build, which was similar to BVP, and it was very successful. RECS applied design-build again in 1999 in response to the Department of Administration's push on the Minnesota Retirement System Building. RECS used the design-build method because of its success and the difficulty of the projects.

## Risk

As stated by Gordon Christofferson, "If evaluating the risks associated with various delivery methods, BVP applied to a CM at Risk/Design Build delivery method would yield the lowest risk since the contractor is involved during the design phases and the project is fully designed prior to the CM soliciting bids for the project."<sup>2</sup> The first step in eliminating risk is the "boiler-plate" contract front ends, which are the general conditions of the contract. The second step occurs with the supplementary conditions that are developed to enhance the general conditions. The third step occurs during the RFB qualifications process where the responders are asked to identify risks in the project and how they will mitigate them. Contractors are asked to find as many risks as possible. On the RFB, RECS & MMD evaluate the project priorities and the point system accordingly. They have the mandatory requirements, pass/fail, and scoring system. The mandatory requirements are basically in the general conditions section. The pass/fail relates to safety requirements by the contractor. An example of pass/fail experience was for the abatement contractor: minimum requirement to provide customer confirmation of two projects similar in nature of \$200,000 or more completed in the last thirty-six months. Three of the four bidders had the same abatement contractor, and a few of the numbers were off for a few of those bidders.

---

<sup>1</sup> Gordon Christofferson, personal interview, October 14, 2008, previously cited.

<sup>2</sup> Ibid.

## Schedule

In comparing to traditional low responsive, responsible bid, the BVP delivery method consumed more time. RECS explained that it was six weeks longer. RECS does feel “This has to be weighed in context of the potential for an underperforming contractor under a low responsive, responsible process.”<sup>1</sup> Regarding construction schedules, it is the goal of a qualifications-based award to yield a contractor who has professional and experienced project managers, schedulers, and superintendents who execute the delivery in the most efficient manner possible.

## Scope Management

The scope clearly varies project to project. The steps for developing the scope do vary and are the same regardless of the delivery method. RECS and the owner work together to develop the scope and then will send an RFP to architects. The architects then work to develop the initial scope further. The steps are as follows: the state contracts with private sector A/E firms for pre-design and design and moving forward through this pre-design stage. Then there is a design process in which the user group interfaces with the design team.

## Time/Cost Relationship

You can achieve two, but it is difficult to achieve all three, of the legs of time-cost-quality relationship. The theory holds that you will often sacrifice one of the three objectives to achieve the other two. For example, if you want a project delivered fast and of high quality, you will pay a premium (sacrifice a lower cost), and if you want the lowest possible cost, you will sacrifice quality and/or time/schedule. In this case, quality is defined as durability or length of lifecycle. BVP scoring uses a 1000-point scale: 400 points for criteria and 600 points for price. The total possible points assigned to price are awarded for the low price response; the high price receives zero, and the prices between receive percentages corresponding to their price relative to the low bidder. The outcome of the bids was that the awarded contractor had the lowest price but the third overall score on the qualifications criteria. The contractor explained that the price points were high because it was “playing defense” on its first BVP project. However, the best value process alone, with pass/fail qualifications, resulted in a “win” since any of the final pool of contractors would have been acceptable. RECS expects that in the future the projects will be weighed differently at 50/50, if not more, toward criteria and less toward price.<sup>2</sup>

## Change Management

As on every project, change management is a number one concern. RECS tried to model its BVP to be similar to the University of Minnesota’s PIPS program. RECS asked all contractors to find and explain their minimization of the risks. Then the awarded contractor must minimize all risks found without changing its bid price: “A more defined scope per project equals better cost control,” as stated by Gordon Christofferson.<sup>3</sup> RECS explained that the best management tool is the completion and thoroughness of the construction documents and the criteria package that is used to bid and construct.

---

<sup>1</sup> Ibid.

<sup>2</sup> Minnesota Department of Administration RFP, previously cited.

<sup>3</sup> Gordon Christofferson, personal interview, October 14, 2008, previously cited.

## Separation of Responsible Parties

Separation of responsible parties is explained by the different contracts with the parties involved. It varies from project to project and contract to contract. Overall, the owner has a contract with RECS, who contracts out to architects and general contractors.

## Conclusion

Overall, use of the BVP process has been successful for the Minnesota Department of Administration. The latest project has been awarded, but construction has not started.<sup>1</sup> This is the Department's first project using 16C.02 subd. 4a best value procurement. The Department feels that using this delivery method has already been beneficial even though the project hasn't been completed. The one example it uses is that all contractors were asked to define their construction process and list their activities for the job. One contractor proposed opening a portion of the roof to access an area to work on structural support. The Department of Administration did not agree, stating that this opening would cause disruption to the building tenants. The Department did not allow this process, and it would not have been caught until construction if BVP had not been used. BVP encouraged the contractor to go more in depth into the project, and it did so by finding a less costly process for the state transportation project. Thus far, there have been no comments by the contractor. This is the awarded contractor's first project for the Department of Administration and also its first using the BVP delivery method.

This is the Department of Administration's first project, and it is learning lessons from it. The department has learned to be more specific in its construction documents and to clarify everything in the RFB. This project was re-bid due to a mistranslation by one contractor in the RFB. This delayed the project, but the department says it was only a small "hiccup" in this BVP method. It is trying to mimic the University's PIPS program and minimize as many change orders as possible. The department emphasizes its contractors' score criteria. It deems this necessary for future projects and feels this will be very beneficial in the long run since the Transportation Building is located on the Minnesota Capitol campus. The Department is considering use of the BVP method in a high-risk, high-profile area.

Three lessons have been learned so far from the Department of Administration's project. For future projects it hopes to do the following:

- Simplify requirements for responders; it was felt the criteria categories were good, but there were too many sub-criteria in each category
- Simplify verification of responses; the mandatory criteria for this project were difficult to analyze
- The Department plans to consider the weighing of criteria score and price. It was defensive on its first project and plans to be more objective, using criteria scoring as a higher percentage of overall score. On this project 40/60 was used, and it was felt that that was too heavy on the price side

## Sources

Mr. Wayne Waslaski, senior director, Real Estate and Construction Services, Minnesota Department of Administration; phone 651-201-2548, [wayne.waslaski@state.mn.us](mailto:wayne.waslaski@state.mn.us)

Mr. Gordon Christofferson, construction program manager, Real Estate and Construction Services, Minnesota Department of Administration; phone 651-201-2380, [gordon.christofferson@state.mn.us](mailto:gordon.christofferson@state.mn.us)

---

<sup>1</sup> Editor's note: as of the interview.



Mr. Sean Rivard and Mr. Thomas J. Hinz, student team

## **Introduction**

MnDOT is one of the major players in the public design-build and best value procurement process. It has been doing this style of construction since the Roc52 project in 2001. With the completion of the twelve-mile stretch, many benefits came to light. These benefits included an accelerated opening date, about \$30 million in savings, and a reduction in inconvenience and stress throughout the process. Based on the results of Roc52, MnDOT has done a total of seven best value design-build projects, totaling more than \$860 million. Some of these projects were Highway 52 in Oronoco, I-494 West Twin Cities Metro, T.H. 10/32 interchange, and Highway 212. According to Jay Hietpas of MnDOT, all of these design-build, best value projects have been successful whether it was a lower-cost, quicker schedule or, in some cases, both. The success of these projects led to the decision that the best procurement method for the new I-35W Bridge would be design-build, best value.

## **Solicitation**

Immediately after the bridge collapsed, MnDOT started putting a team together to run the project. The decision was made to use design-build best value, and requests for qualifications (RFQs) were sent out. The RFQ stated, "The project is anticipated to consist of: Reconstructing a major river crossing with 5 lanes in each direction with shoulders over the Mississippi River with minor grading, hydraulics, utilities, ITS, lighting, paving and other miscellaneous work." In order for the contractor to be qualified, it needed to meet the following requirements:

- Able to meet an aggressive project delivery schedule
- Committed to quality
- Having proven experience in the design and construction of major river crossings
- Having familiarity with innovative design-build approaches to ensure timely completion
- Willing to partner with federal, state, and local agencies for mutual success<sup>1</sup>

MnDOT told all contractors that the process would be design-build with an A+B clause having a no-excuse bonus. This meant that the clause had two elements: A is price, and B is schedule. All contractors were notified that their schedule must be within the 337-437 calendar days range. MnDOT set each day at a value of \$200,000. The formula used these components in the equation  $(\text{Price} + \text{Days} (\$200,000) / \text{Technical Score} = \text{Adjusted Score}$ . The RFQ also stated what the statement of qualification must contain and how it must be presented. The contractors were also notified that all unsuccessful bidders would receive a stipend of \$300,000. This would go only to contractors that submitted a responsible proposal. Only five companies submitted RFQs, and four of them eventually submitted bids: Ames/Lunda, C.S. McCrossan, Flatiron/Manson, and Walsh Construction/American Bridge.

---

<sup>1</sup> MnDOT Power Point presentation outlining process. [dot.state.mn.us/i35wbridge](http://dot.state.mn.us/i35wbridge)

## Qualifications

After the qualifications were received, MnDOT sent out RFPs to the five companies. In the proposals were several requirements, broken into the categories project goals, estimated cost, schedule, DBE/EEO requirements, and design requirements. Included in the project goals were safety, quality, aesthetics, public relations, innovation, and partnering. MnDOT set the estimated cost requirement between \$200-\$250 million and the schedule requirement at a maximum of 437 days. The design requirement specified that the bridge structure must be either concrete or steel. The proposals were broken out into four different criteria: quality, aesthetics, enhancements, and public outreach.

Quality: 50%

- Experience of key individuals
- Extent of quality assurance
- Safety
- Measures to evaluate performance

Aesthetics: 20%

- Visual enhancements to bridge
- Involvement of public after letting

Enhancements: 15%

- Roadway enhancements
- Structural enhancements

Public Outreach: 15%

- Impacts on public
- Approach to communications

All proposals were to meet the above criteria and would be scored on how well they addressed each aspect.

## Transparency

Transparency is very important when using best value procurement. By keeping the process as transparent as possible, the scoring of the contractor's proposals is more legitimate. MnDOT had an evaluation plan for the bridge that stressed transparency. It started with creating a technical review committee (TRC). Four members were from MnDOT, one was from the City of Minneapolis, and one was from the AGC. This gave the team a diverse background and represented a variety of stakeholders, although there were some complaints that the public was not included on the TRC. Each member received the proposals from Ames/Lunda, C.S. McCrossan, Flatiron/Manson, and Walsh/American Bridge. The next two steps are the areas in which the transparency seems inadequate. After the TRC members were given the proposals, they were allowed to discuss their contents and then interview the proposers. Jay Hietpas said these interviews were needed in order to clarify the "grey areas" in the proposals. The proposers were not allowed to enhance or add items to their proposals during these interviews. The TRC members could have been swayed by talking with fellow members about the proposals or by the presentations put on by the different contractors.

The following diagram<sup>1</sup> explains the process that MnDOT used while evaluating the proposals.

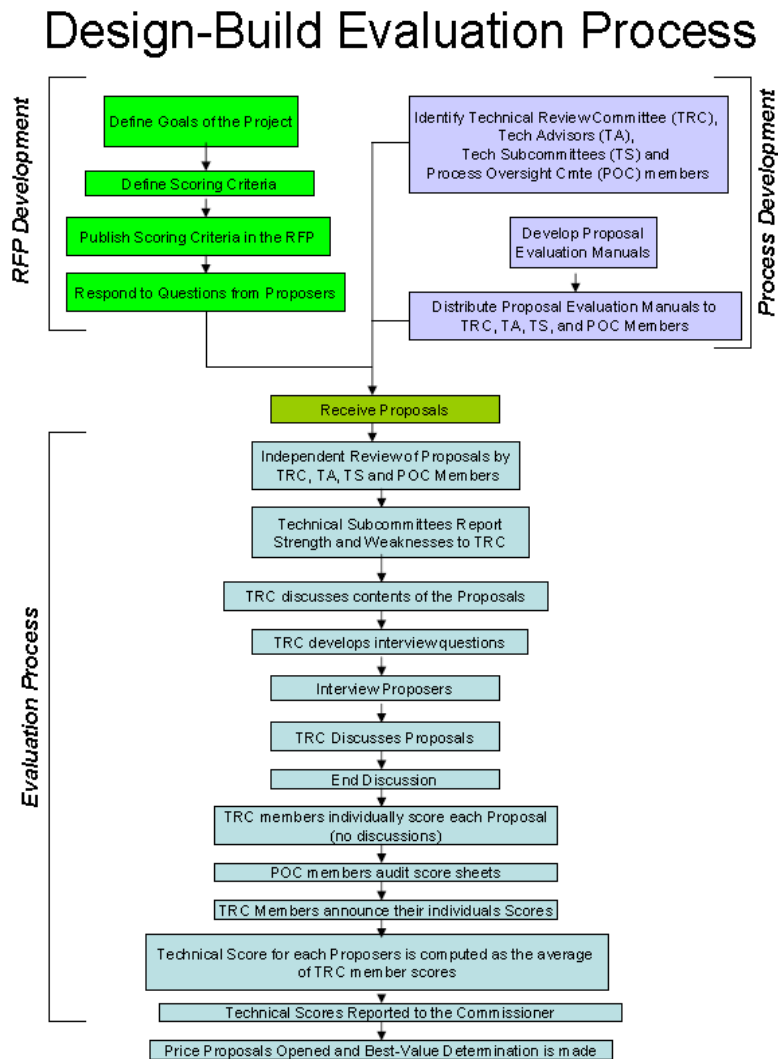

This process resulted in a score that based not solely on the technical aspects of the proposal but also on the quality of presentation and interview. It appears that it would have been more transparent if there had been no interaction between TRC members or between TRC members and the contractors before the technical scoring was completed. After the TRC members had completed the discussions and interviews, they reviewed the proposals, giving them scores based on quality, aesthetics, enhancements, and public outreach. The scores were audited by a third party and then tabulated. Only after all scoring had been completed and audited did the TRC look at the price proposals and factor price into the equation. This helped take out any bias towards the lower bidder.

<sup>1</sup> [projects.dot.state.mn.us/35wbridge](http://projects.dot.state.mn.us/35wbridge)

Following is a summary of the best value determination using the A+B formula divided by the average technical score.

S.P. 2783-120 - ST ANTHONY FALLS (35W) BRIDGE DESIGN-BUILD PROJECT

Proposer	Technical Proposal Score	Price Proposal 'A'	Time (Days)	Time (Days x \$200,000) 'B'	Adjusted Score (A+B) / Technical Proposal Score Low Score = Best Value
Ames/Lunda	55.98	\$ 178,489,561.00	392	\$ 78,400,000.00	4,588,952.50
C.S. McCrossan	65.91	\$ 176,938,000.00	367	\$ 73,400,000.00	3,798,179.34
Walsh / American Br.	67.88	\$ 219,000,000.00	437	\$ 87,400,000.00	4,513,847.97
Flatiron / Manson	91.47	\$ 233,763,000.00	437	\$ 87,400,000.00	3,511,129.33

### Delivery Method

MnDOT chose to use design-build on this project for many reasons, including schedule, cost, and quality. This process had been very successful for it in the past, and with the accelerated schedule, it seemed to be the best fit. By using design-build the contractor can fast track its schedule. This is possible because with design-build, the construction can happen before the drawings are completed. With traditional design-bid-build, the construction documents need to be completed before the bid process or the construction can begin, resulting in a longer schedule. With design-build the construction can begin with unfinished drawings and continue as the drawings are being completed. This was a major reason why MnDOT chose design-build for the I-35W Bridge: it saw the importance of getting the bridge completed as quickly as possible.

### Scope Management

Normally with a project there will be scope management changes that increase the schedule and the cost. MnDOT made sure it addressed everything it could at the beginning so there would not be large changes in the scope. Jay Hietpas stated, "Scope management comes down to how well we write the RFP." If the RFP is well written and concise, there will not be drastic changes during the project. Changes can sometimes come from local units of government. For example, on the I-35W Bridge the local government wanted a new water line under the highway. With design-build best value, there is less cost growth than with the traditional design-bid-build. The owner is able to verify with the contractor that the proposal is matched up with the project scope and goals. With design-bid-build, often only the price is seen. In order to lessen the costs of change in the I-35W Bridge project, MnDOT used a "no-excuse bonus" as part of the contract. A no-excuse bonus is an incentive that keeps the contractor from filing claims against the owner. In order for a contractor to receive the bonus, it must waive all claims against the state. A claim is a dispute over extra work costs that the owner does not agree to. This is different from a change order. A change order is something that MnDOT has agreed to and for which it is willing to pay the costs for the extra work. An example of this is change to the scope of work.

## Time/Cost Relationship

Using the traditional design-bid-build method for a project like the I-35W Bridge would have caused a longer time gap from the bridge collapse to completion of the new bridge. MnDOT found it beneficial to use design-build to shorten the construction phase of the project. MnDOT was under an unusual time crunch and needed new plans for a bridge as soon as possible. With four contractors doing so much work early on in the project, MnDOT offered \$500,000 stipends to the losing contractors for their hard efforts and engineering ideas, should MnDOT find them useful to the project.

Another factor was the cost to the state and local economy of the bridge being out: approximately \$400,000 a day in increased vehicle gas use, wear and tear on alternate routes, and maintenance on those alternate routes. The bridge was out for 413 days, so the total cost of not having the bridge fully operational was \$165,200,000. This does not include the economic impact on area businesses. A study conducted by DEED and MnDOT showed that in 2007 Minnesota had a \$17 million loss. In 2008, that number escalated to a monster \$43 million.

Choosing the right method for building the bridge and putting in the extra time and money in the front of the project resulted in a huge savings for MnDOT. The result of the conversion of the stipends into cost of the bridge outage per day was less than four days' worth.

$$\$1,500,000 \text{ (stipends)} / \$513,000 \text{ (outage cost per day)} = 2.92 \text{ days.}$$

If MnDOT had chosen a different method of building the new bridge, it could have cost taxpayers more money. How much more, we will never know, but the cost of having the bridge out was adding up to big numbers quickly.

## Change Management

With any project come change orders. How many and how frequently are the questions that contractors, architects, and owners have been dealing with for years. MnDOT has come up with a good way to manage this problem: it has developed a program called "no-excuses bonus." This bonus reduces contract time by tying a bonus to the completion of construction activities, which might or might not be the contract completion date. If MnDOT is the cause of delays that relate to this new time frame, the contractor is not penalized. All other actions that are related to time overrun are to be viewed as project risk. A huge advantage of using a program like this is that the time it takes to file a change order is greatly reduced. It is not necessary to submit a change order, then wait for a reply, and wait to get money for extra cost in labor and materials. All this down time adds up and can easily bring a project behind schedule.

MnDOT uses the no-excuses bonus only on unique jobs; it finds it to be a huge money saver. MnDOT has used it on ROC 52 in Rochester as well as on the new I-35W Bridge. The average rate of change orders on a job is 8%; with the I-35W Bridge, MnDOT did not have to deal with change orders, because Flatiron took care of all of them. This was not free for MnDOT—it paid Flatiron \$7 million—but if this cost is taken as a percentage of the total project value, it is only 2.99% of the total, which is less than the national average. MnDOT likes this program because it guarantees on time or early completion of the project. It also believes this bonus enhances projects that have high impact. Overall MnDOT thinks this program works very well and knows it has saved the public money.

## **Risk**

MnDOT took two approaches to reduce risk on the I-35W Bridge project. First, it selected a design-build method over a traditional design-bid-build method. By doing this, MnDOT shortened the work schedule as compared to the traditional method of building. The amount of time that was saved is not known, but with the bridge out and a daily cost of \$400,000, it was adding up to a big number. MnDOT used design-build on the ROC52 project in Rochester and saved two years on the project schedule.

Secondly, MnDOT used a bonus incentive system. One bonus was to encourage the contractor to have the project completed on or before the due date. For the I-35W Bridge the bonus was \$200,000 a day, up to \$20,000,000. The bonus may seem unnecessary, but considering the cost of the bridge being un-operational, this was a small price to pay. The second bonus was the no-excuses bonus. MnDOT used it as a way to reduce change order costs. MnDOT told the contractor that if it didn't initiate any change orders, MnDOT would give them this bonus. These bonuses can be a very helpful tool to use for unique projects.

By using design-build and having the bridge completed early, with no change orders, MnDOT reduced its risk. The risk from having the bridge out of operation was growing daily, not to mention that a change order log for this accelerated project could have been huge. However, with the bonus system, change orders were not an issue and were mostly handled by the contractor. MnDOT minimized its risk in this project by using simple techniques.

## **Schedule**

With any project, schedule is a key component for success. MnDOT has developed its design-build system to shorten a project schedule compared to a traditional design-bid-build method.

### **Advantages**

- Establishment of timelines helps set internal and external control for the project
- Condensed schedule requires a concentrated effort and forces decisions and actions to be made by responsible parties

### **Disadvantages**

- Establishment of dates that create accelerated timelines by the department may not provide sufficient time for the proposers to adequately address the proposal needs—the more complex the project, the greater the effect
- Condensed schedule increases risk to the proposer during bid preparation

With design-build, MnDOT feels it gets more advantages than disadvantages. To minimize the disadvantages, MnDOT has added different incentives to the contractor to get the project done early or to guarantee completion on time. One example would be the no-excuses bonus. After MnDOT finished the ROC52 project, it had a few recommendations to make future schedules flow even better.

## Recommendations

- Allow at least four months for proposers to develop a proposal from the Department's RFP distribution package.
- Establish submittal dates for innovative alternative technical concept (ATC) submittals that maximize the potential benefit to both the Department and proposers.
- Allow at least six months for the Department's preparation of an RFP package after risk allocations have been assigned.

These recommendations cannot always be incorporated into a project. With the I-35W Bridge, all processes had to be accelerated, and there was not enough time to incorporate all the recommended procedures. The project was still completed ahead of schedule, showing how much more efficient design-build is compared to other methods of construction and how it can be flexible to fit a wide range of situations.

## Separation of Responsible Parties

The I-35W Bridge was a unique situation, and the owner, architect, and contractor had a unique relationship as well. In a typical design-build project, the owner picks a design/construction firm in such a way that the architect/engineer along with the contractor hold one contract with the owner. With the new bridge, a hybrid was formed. MnDOT held a contract with a third-party inspection firm, and also held a contract with Flatiron. By hiring the third-party inspection firm, MnDOT's separation was not as important, because the firm took some risk of checking Flatiron's work. If something were to go wrong, the third-party firm would have some responsibility, which means less responsibility and risk to MnDOT. Disputes between the relationships are significantly reduced as well, so the separation was not terribly important.

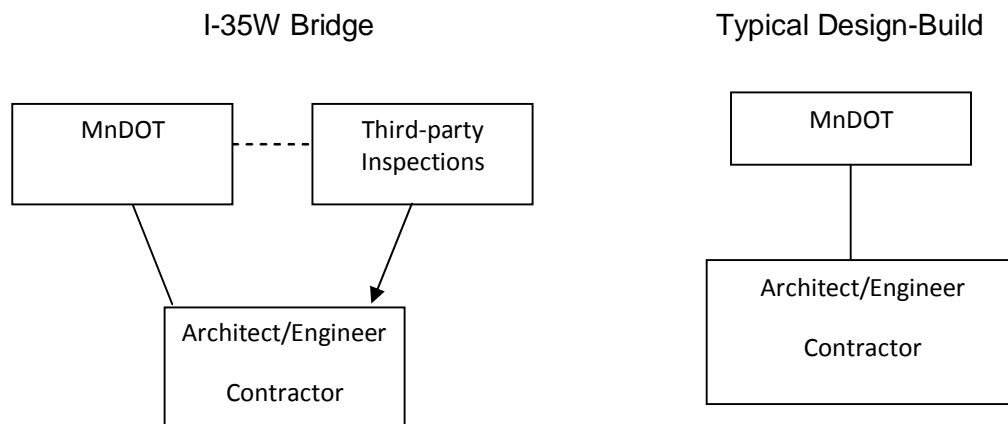

## Works Cited:

Minnesota Department of Transportation. December, 2005. *Innovative Contracting Guidelines*.  
<http://www.dot.state.mn.us/const/tools/documents/Guidelines.pdf>

Minnesota Department of Transportation. November, 2007. Interstate 35W Bridge—Contractor Selection.  
<http://www.dot.state.mn.us/i35wbridge/rebuild/contractor.html>

University of Minnesota best value procurement seminar, September 10, 2008 presentation. St. Anthony Falls I-35W bridge replacement. Terry L. Ward, MnDOT deputy project manager

Sean Rivard and TJ Hinz interview with John Chiglo and Jay Hietpas, 23 September 2008. MnDOT's best value procurement process.

Mr. Tyler Safratowich and Mr. Daniel Spa, student team

## Introduction

When researching the University of Minnesota and the Arizona State University (ASU) performance information procurement systems (PIPS), we found a best value system that incorporated a win-win relationship between the owner and contractor. The PIPS system started as an ASU research group project led by Dean Kashiwagi, who had a vision of creating a full-information environment for all of the parties within a project. This system allows information to be used to bring best value to the owner while also maximizing profit to the contractor. ASU set up the Performance Based Studies Research Group (PBSRG) in 1994, which created the best value PIPS system. Prior to 2005, the University was searching for a system that would increase the level of efficiency in project management and construction. It discovered the leader in best value, Arizona State University, and has used ASU's PIPS program to

- Minimize risk.
- Increase performance.
- Increase efficiency.

## History

ASU first began to consider a best value system when it saw a need to enhance efficiency and performance and minimize risk during the procurement stage of a project. ASU developed models to help define, measure, analyze, improve, and control the performance of services, vendors, and personnel. These models are used to

- Reduce client management requirements.
- Create an effective risk transfer and minimization framework.
- Assist in defining performance and value (for entities, departments, vendors, or individuals).
- Establish accountability through measurement.
- Motivate continuous improvement.
- Increase organizational efficiency.

The best value system has primarily been used in construction, but can be used by other entities and establishments including universities, states, cities, and major companies such as United Airlines. The best value PIPS program was discovered by the University Capital Planning Project Management (CPPM) program as a way to save money, lessen change orders, and increase satisfaction of project stakeholders, things that were direly needed (CPPM Web site). The University has since been training with ASU to become a leader in the PIPS program and use it to better procure and manage projects on campus. The best value PIPS program does not affect the University's internal project management structure, but rather gives the project manager another option for procuring and giving projects to the right contractor for the job. PIPS best value can be used with several of the traditional delivery methods such as design-bid-build, design-build, or construction manager at risk (CMAR).



## Overview

The PIPS best value system comprises the following six phases:

1. Setup and education in the process
2. Collection of past performance information (PPI)
3. Bidding and analysis of bids
4. Selection of the best value contractor
5. Pre-award
6. Construction and rating of construction

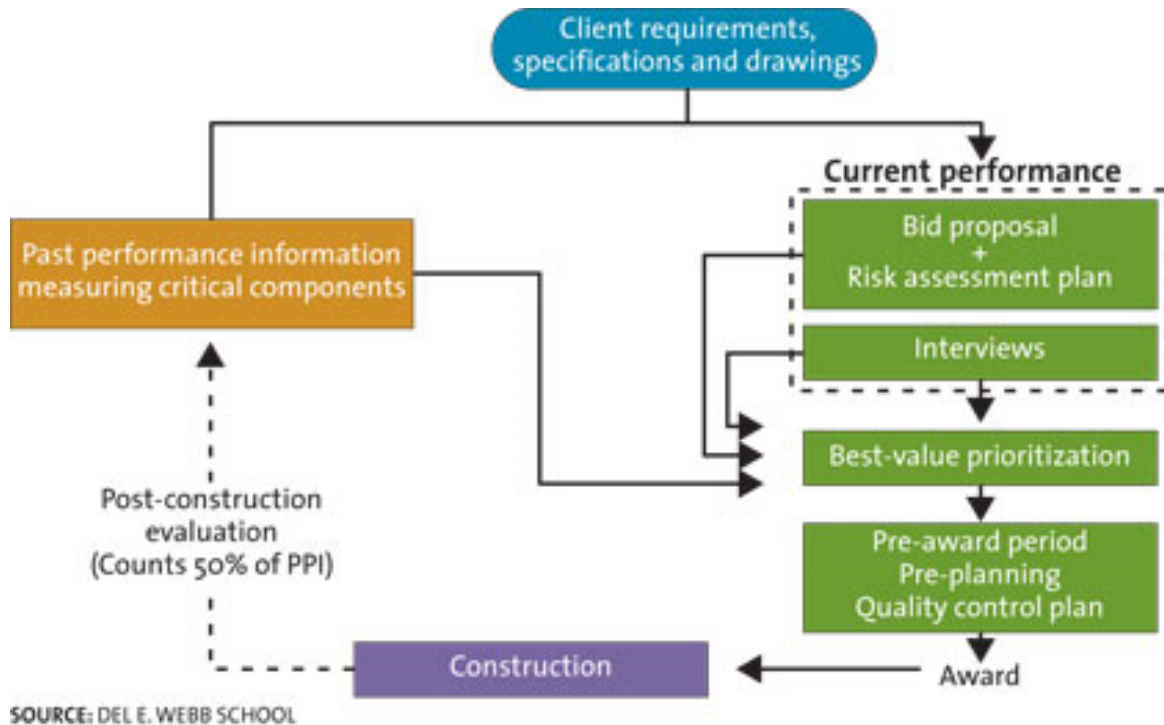

By directly following these phases, PIPS will minimize the decision-making in the project by the owner, due to the fact that the contractor has already thoroughly gone through any situation that could arise in the construction phase. In turn, there will be fewer change orders or unforeseen circumstances.

The best value PIPS system has been a good choice for both agencies so far. According to the numbers, the University has reduced project cost, contractor cost/schedule increases, and owner risk and has increased customer satisfaction to 98%. The University and ASU see the PIPS program as something very positive compared to the previous methods of project management (pbsrg.com).

## University of Minnesota Statistics (November 2008)

Number of PIPS procurements	77
Awarded cost vs. proposal cost	-3.2%
Projects where best value was also lowest cost	56%
Completed projects	52
Number of projects with no contractor cost increases	50
Cost increases (client/contractor)	3.7%/0.1%
Schedule increases	43.8%/5.9%
Number of qualified vendors	84

### Advantages

The University uses PIPS on 20-30% of its projects. Project managers decide whether or not they want to use PIPS on a project. If they do, then the process is followed; if not, they will use another procurement system that best fits the project, its stakeholders, and its time/budget constraints (Kaai presentation).

The perceived strengths of the PIPS program are, according to Kashiwagi

- Ability to implement pieces of the program if unable to implement full program
- An information-based procurement system for selecting high-performing contractors
- Ability to award to quality and price
- Detailed pre-planning
- Minimized risk
- Minimized change orders
- Objective system
- Pre-qualified vendors
- Use of measurements on projects, vendors, clients, and staff to manage projects

These strengths allow the owner of a project to mitigate nearly all risk, pass it on to the contractor, and rely on the contractor's successful past performance, responsibility, and cooperation.

### Disadvantages

Along with many positive aspects, the PIPS program also has some perceived weaknesses:

- Buy-in from management and staff is hard to obtain.
- Extensive training is needed to implement a full program.
- Can only move as fast as the organization and industry is willing to move.
- Is time consuming.
- Pre-planning is required—more work and time up front.
- Takes longer to award.
- Emphasizes writing ability.

During our research we have been in contact with contractors familiar with the process whose opinion of PIPS did not reflect the positive promises PIPS has to offer. The contractors, who did not want to be identified, said that although the system works to reduce risk to the owner, it still has some perceived flaws. Some of the contractors' main perceptions are as follows:

1. Initial PIPS request takes up to 2-3 weeks, much longer than for normal RFPs.
2. Scoring system is not always defined, and scorers are unknown.
3. If proposal is over budget, proposal is negated.
4. If awarded the project, contractor must be able to answer other contractor's risk assessment and value added (RAVA) plans. There is no profit for the extra time and effort the contractor puts forth.
5. Unforeseen conditions are viewed as a "black mark" for the contractor if not included on the RAVA plan; PPI goes down.
6. General contractors, if awarded the project, can subcontract out to anyone, including non-PIPS contractors.
7. Can take up to 3-4 weeks to find out if the job has been won or lost; can hinder decisions for other projects for contracting company.<sup>1</sup>

These are some of the areas where contractors feel that the PIPS program fails to do as well as advertised. Although the proposal preparation process takes longer, contractors tend to bid the job the same way for fear of overpricing. Contractors feel that the PIPS program is a good system, but needs to be more flexible to be able to address some of its flaws, namely, too much time spent in the project setup process, the collection process, and the pre-award phase (University contractor).

## Solicitation

The solicitation in a PIPS project begins with the project manager deciding to use the best value system. PIPS contractors then must be qualified, a subject that is discussed in depth later. Once qualified, contractors are notified and can decide whether they would like to pursue a project by submitting a proposal. The past performance information (PPI) and proposal preparation process begin simultaneously. The proposal and PPI phase happens as follows (filters 1-3 on Quality/Time graph):

- RFP is prepared.
- Project educational meeting and pre-proposal site walkthrough take place.
- Directions for PPI information given.
- PPI information submitted.
- Pre-proposal meeting held.

---

<sup>1</sup> Editor's note: Ms. Nacole Kaai of the University's PIPS program reviewed these perceptions and countered that most are truly misperceptions, stating:

1: The advertisement time is the same as for traditional RFPs.

2: All scoring weights can be found in any RFP that we put out. How a contractor will be evaluated is also found in every RFP that we advertise. We have never stated who scores an RFP, instead stating a team will do so.

3: The exclusion of over-budget proposals has been changed to now incorporate proposals that are over budget.

5: This is only true for conditions that are within the contractor's control. A hidden condition or owner condition would not have any effect on the contractor's PPI score.

6: The University does not dictate who a general contractor uses as a sub. If a general contractor wants to use a non-PIPS subcontractor, it has the ability to do so since it is in control of choosing its team.

7: A preliminary notice is posted online before the award is made regarding the project and what vendor was chosen to participate in the pre-award phase.

- Proposal submitted (proposal shall include RAVA plan, bid price, legal documents/requirements, and team composition).
- Proposing contractors and owner interviewed.

## Quality/Time

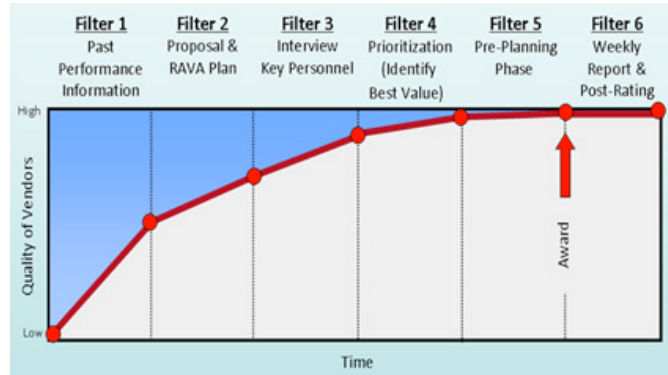

This graph shows how PIPS will gain quality in a project over time by having the proposing contractors go through “filters” (Kaai presentation). After completing these filters, the owner will theoretically have the most qualified contractor for the project. How the contractor becomes the most qualified through these specified filters will be discussed in the next section.

## Qualification

Any contractor that wants to propose on a PIPS project must first go through the initial past performance information (PPI) step, which is also known as the request for qualification (RFQ). In this step, the proposing contractor gathers information on all critical components of a project, including references, management, prime contractor’s information, and ability to successfully finish a project (view PPI Survey for an example). Contractors can survey up to 25 of their past projects to gather information to best display their company’s talents and abilities (Kashiwagi).

After the RFQ process and submission of a proposal, qualified contractors can be interviewed by the client regarding any specific questions about the proposed project, if required. An example of the qualification-weighting scheme is as follows (Kaai presentation).

- 20% price
- 80% performance
  - Interviews 25%
  - RAVA plan 25%
  - Past performance 15%
  - Schedule 5%
  - Equal opportunity 5%
  - Safety 5%

If a contractor wishes to propose on a project, it must also submit a risk assessment value added (RAVA) plan. This plan, in large part, is the basis on which its proposal will do well or not. The RAVA is two pages and fully explains the contractor’s ideas on how it will assess and handle any risks that may arise during the project and also what it can do to give the owner more value within the project.

## Survey Questionnaire – University of Minnesota (Construction Services)

	Survey ID
<b>To:</b>	
<i>(Name of person completing survey)</i>	
Phone:	Fax:
<b>Subject: Past Performance Survey of:</b>	
<i>(Name of Company)</i>	
<i>(Name of Project Manager)</i>	
<i>(Name of Site Superintendent)</i>	

The University of Minnesota is implementing a process that collects past performance information on firms and their key personnel. The information will be used to assist the University in the selection of firms to perform various projects. The firm/individual listed above has listed you as a client for which they have previously performed work on. We would appreciate your taking the time to complete this survey.

Rate each of the criteria on a scale of 1 to 10, with 10 representing that you were very satisfied (and would hire the firm/individual again) and 1 representing that you were very unsatisfied (and would never hire the firm/individual again). Please rate each of the criteria to the best of your knowledge. If you do not have sufficient knowledge of past performance in a particular area, leave it blank.

<b>Client Name:</b>	<b>Completion</b>
<b>Project Name:</b>	<b>Date:</b>

NO	CRITERIA	UNIT	
1	Ability to manage the project cost (minimize change orders)	(1-10)	
2	Ability to maintain project schedule (complete on-time or early)	(1-10)	
3	Quality of workmanship	(1-10)	
4	Professionalism and ability to manage (includes responses and prompt payment to suppliers and subcontractors)	(1-10)	
5	Close out process (no punch list upon turnover, warranties, as-builts, operating manuals, tax clearance, etc. submitted promptly)	(1-10)	
6	Communication, explanation of risk, and documentation	(1-10)	
7	Ability to follow the users rules, regulations, and requirements (housekeeping, safety, etc...)	(1-10)	
8	Overall customer satisfaction and comfort level in hiring vendor/individual again	(1-10)	

<b>Printed Name (of Evaluator)</b>	<b>Signature (of Evaluator)</b>
------------------------------------	---------------------------------

Thank you for your time and effort in assisting the University of Minnesota in this important endeavor.  
**Please fax the completed survey, no later than XX-XX-08 to: XXX XXXX at Fax # (XXX)-XXXX**

In PIPS best value, the RFP stresses that contractors understand the owner’s definition of performance and not only meet that definition, but go above and beyond. This is the “value-added” part of RAVA; the other part is the “risk assessment.”

After submitting the completed proposal, the contractor and its key personnel involved in the project may have an interview with the owner to discuss the critical components of the project. This part is comparable to the traditional process, which would include the correct legal requirements, price, names of participants, and general schedule. This is considered “filter 3.”

Filter 4 is an important part of the PIPS process, in that it is the arithmetical determination of the best value through filters 1-3, and is calculated by the Arizona State University. This is a part of

the bidding process where the actual RAVA plans come into play. The contractor is able to convey its quality by illustrating that it has “covered every corner” regarding any risk that could happen during the project’s duration. This RAVA includes five major components, according to Kashiwagi:

- Identification of the risk that the contractor will not finish on time, on budget, and meeting quality expectations
- Method of risk minimization
- Value engineering
- Cost breakout
- Construction schedule

How a risk develops, and how that risk can be quantified in terms of cost, time, and quality, are questions that should be answered by the contractor in its risk assessment plan and also in the interview.

Added value, the second part of the RAVA plan, goes into depth on how the contractor not only comes close to the owner’s base bid, but also how value can be added to the project while still considering risk factors.

**Transparency and Neutrality**

The evaluation of the RAVA plan and the subsequent determination of the best value is done “blind,” with no knowledge of the contractor’s identity, in order to eliminate any bias (Savicky e-mail). The RAVA plans and the proposal documents, including price, are separated. If the RAVA plans do have company names on them, the proposal will be viewed as non-responsive. Each RAVA plan is then marked with a number, signifying it as a valid plan to be reviewed. Each member of the predetermined rating team must sign a form stating that they have no previous knowledge of any of the contractor’s bid. The RAVA plans are then graded based on a 1-10 scale, with 10 signifying the absolute best value in that section of the plan. With the plans being graded blindly, the process allows contractors to be truly assessed on the front-loaded work that they have completed on evaluating the project and minimizing risk while adding value.

The evaluation criteria listed below are rated on a scale of 1-10, with 10 being the best and 1 being the worst. The RAVA plans are rated comparatively. All plans should start from an average (or 5) rating and go up or down depending on the relative value. If a plan stands out, it should get a 10. If the rater feels that the quality of the plan does not satisfy minimal performance expectations, it should be rated a 1. (Note: If the vendors do not clearly differentiate themselves from one another, the client should give all of the raters the same score.)

Example of Score Sheet

No	Criteria	Scale	Firm A	Firm B	Firm C	Firm D	Firm E
1	Identification of unique/potential risk areas	1-10					
2	Vendors plan to minimize the potential risks	1-10					
3	Increase of value (cost reduction or added quality)	1-10					
4	Overall value that the RAVA plan provides	1-10					

## Delivery Methods

The PIPS system does not attempt to replace other delivery methods, but rather to give an option to perform those delivery methods in a better, more efficient way through procurement. PIPS is a selection tool that can be applied in design-bid-build, design-build, CM at risk, or time and material contracts. This system also affords CPPM project managers the ability to use any type of delivery method that fits best with their project and subcontractors.

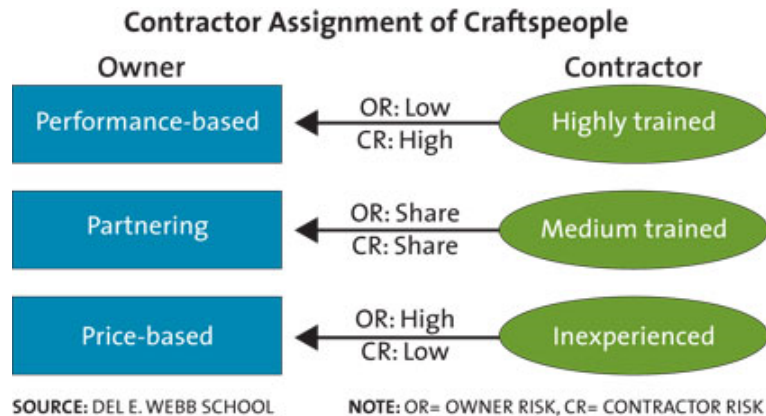

The figure above gives a simplified example of how the owner and contractor risk is disbursed with differing quantities of contractor training. According to the PIPS system, with a highly trained contractor the owner will have passed most, if not all, the risk to the contractor. In return, the contractor will receive a performance-based contract and will move away from a strictly price-based contract.

## Risk

As discussed before, risk is minimized with the use of the two-page RAVA plan. The PIPS process is prized for being more efficient, primarily due to the fact that it minimizes risk. The RAVA plan attempts to minimize risk with pre-planning and discovering risk before it even happens. All construction projects are unique, so risk should be identified according to the owner's expectations, extenuating circumstances, project complexity, and subcontractor performance. The identified risks of a project should be detailed with an explanation of how they might occur, what will happen if they do, how the risk will be avoided/fixed, and how that risk will affect the price, time, or quality of the project.

At the pre-award phase, the contractor is given all risks specified on project by all contractors' RAVA plans, and here can decide if it wants to continue on with the project or take the option of backing out because it feels it cannot cover the risk with its proposed price.

## Schedule

The PIPS process takes longer due to the pre-award phase. Although PIPS takes longer on the front end, it is supposed to lessen schedule-lengthening delays such as unforeseen conditions (risks) and change orders by pre-planning for them.

## Scope Management

In the PIPS program, scope management is shaped by the determination of everyone in the process to have as few change orders as possible. Reducing change orders and surprises (risks) will produce a project that is on time and on budget. The University of Minnesota, before



PIPS was used, was its own worst enemy when it came to changes made on a project. Contractors want to stick with the initial scope and risks involved and stay away from making any scope changes due to the effects it has on their PPI for the next project.

### **Time/Cost Relationship**

The time/cost relationship in the PIPS program is a little different. PIPS is attempting to procure the highest-performing contractor, and so the procurement schedule is much longer. Also the cost can be higher if the best-performing contractor's number is higher than others, because PIPS is not necessarily looking for the lowest price but rather the best value for the price given. The PIPS procurement system is trying to balance cost/schedule and at the same time get the best contractor to complete the project.

### **Change Management**

Change is avoided at all costs by the contractors because change on a project can be viewed as a "black mark" in post-project reviews. Some changes are inevitable, due to unforeseen conditions or owner-directed changes, but these changes do not affect the contractor's post-construction scores (PPI). The University recognizes that not all of the risk can be mitigated.

As for scope changes by the owner, PIPS usually works the same as any other delivery method, where a change order is initiated and approved/rejected by the owner.

### **Separation of Responsible Parties**

PIPS is not in itself a delivery method, but rather a method for procuring the highest-performing contractor. With PIPS, the owner can use any delivery method, resulting in many different situations to explain the separation of the parties. There is the traditional DBB three-legged stool, with the design-builder taking on all risk, or any hybrid of the two.

PIPS places nearly all risk on the contractor at the beginning of the project with the RAVA plans, and also by giving the contractor all the risks from the other proposing contractors. This takes the owner out of the situation unless it decides to initiate a change order for some reason. If it is a design-build project, then almost all risk is essentially placed on the design-build team.

### **Conclusion**

The PIPS program has been seen as a successful implementation due to the metrics stated in the table on page 3. By using this process, the University has been able to lessen project change orders and total project cost, pre-plan for common project risks, add value to projects, and increase customer satisfaction to 98%. Although PIPS is only a procurement strategy and not a delivery method, it has given its users the ability to increase project efficiency and decrease change and total project cost.

Some may view this process as being good for only the owners. Although they can be more time-consuming on the front end, PIPS projects allow time to pre-plan for changes, and therefore the guesswork for contractors is taken out of the equation. The idea is to spend time being proactive on detrimental risk situations rather than reacting to changes in the field. The overall project numbers are very hard to argue with when compared to previous project numbers put together by the University.

PIPS is not a perfect system by any means, but it has performed very well and has been used on many different types of projects. PIPS changes the perception of risk from being something



unknown to something foreseeable and therefore something that can be pre-planned for and mitigated. The PIPS system is an excellent example to follow for anyone attempting a best value procurement project.

### **Works Cited**

Del E. Webb School, comp. Best Value Examples. Digital image. [Pbsrg.com](http://www.pbsrg.com).

<[http://http://www.pbsrg.com/publications/downloads/bv-book/previews/chapter\\_8\\_pips.pdf](http://http://www.pbsrg.com/publications/downloads/bv-book/previews/chapter_8_pips.pdf)>.

Kaai, Nacole. "PIPS - Best Value." PIPS Best Value – U of M and ASU. CMgt. 4550 classroom, Minneapolis. Oct.-Nov. 2008.

Kashiwagi, Dean. Best Value Procurement. 2004.

Kashiwagi, Dean, comp. "Performance Information Procurement System." Arizona State University, PIPS - Best Value. Study Guide. Vol. 2008.

Performance Based Studies Research Group ( [PBSRG](http://www.pbsrg.com)),, Arizona State University. <<http://www.pbsrg.com>>.

Savicky, John. "PIPS Best Value System." E-mail to the author. Oct.-Nov. 2008.

U of M Contractor. "PIPS Best Value Within U of M." personal interview. Oct.-Nov. 2008.

Mr. Randy Faasumalie, student team

Minnesota Statute 471.35, titled the Uniform Municipal Contracting Law, has served as the primary source of statutory regulation of public sector contracts in Minnesota. The statute expressly applies to counties, cities, townships, school districts, and all other municipal corporations and political subdivisions. (Minnesota Association of Townships)

The main purpose of this regulation is to ensure that local units of government get the best price, saving taxpayers money by creating a level playing field and reducing opportunity for government officials to participate in fraud or favoritism.

A careful reading of the list of regulated contracts reveals that while contracts for altering, repairing, or maintaining property are subject to regulation, contracts for professional services are exempt (excluded) from the requirements of the statute. In fact, the Minnesota Supreme Court has confirmed that architectural services are not subject to the requirements of Minnesota Statute 471.345, even though they may appear to be so for construction.

While cities and townships are generally required to award any construction-related bids (other than design contracts) to the lowest responsible bidder (Minn. Stat. 365.37, 412.311), this does not necessarily mean that they are automatically bound to the lowest price submitted. The courts have repeatedly recognized a need to allow the governing body some discretion in determining the lowest responsible bidder, especially when exact bid specifications are not possible. (Minnesota Association of Townships)

This discretion is in recognition that the lowest price does not always equal the best value and is, therefore, not always in the best interest of the public. The requirement that the bidder be “responsible” protects cities and counties from having to choose unqualified or unscrupulous low bidders. It allows the city or county to consider other factors, such as the bidder’s financial responsibility, integrity, skill and ability, and likelihood that the bidder will work responsibly. The city or county can even include evaluation criteria for “responsible” bidders in the bid specifications.

In 2007, the Minnesota Legislature authorized cities and other governmental entities to use a best value procurement (BVP) process for “construction, building alteration, improvement, or repair [and maintenance] contracts.” (Minn. Stat. 412.311). This alternative procurement process is being phased in for various types of local governmental entities. For cities, counties, and large school districts, BVP became available on July 1, 2007.

BVP is a process based on competitive proposals that awards the contract to “the vendor or contractor offering the best value, taking into account the specifications of the RFP, the price and performance criteria set forth in Minn. Stat. 16C.02 and described in the solicitation document.” (State of Minnesota, Office of the State Auditor). The price and performance criteria may include, but are not limited to,

- 1) The quality of a contractor’s performance on previous projects
- 2) The timeliness of the contractor’s performance on previous projects
- 3) The level of customer satisfaction with the contractor’s performance on previous projects
- 4) The contractor’s record of performing previous projects on budget and its ability to minimize cost overruns

- 5) The contractor's ability to minimize change orders
- 6) The contractor's ability to prepare appropriate project plans
- 7) The contractor's technical capabilities
- 8) The individual qualifications of the contractor's key personnel
- 9) The vendor's or contractor's ability to assess and minimize risks

If an interview of the vendor's or contractor's personnel is one of the selection methods, the relative weight of the interview must be stated in the solicitation document and applied accordingly (Minn. Stat. 16C.28, subd. 1(c) (2008)).

There appears to be a lot of interest by the cities and counties of Minnesota in learning more about BVP methods and applications, primarily for larger, more complex projects. This interest has not translated into action, however, due to various obstacles in the adoption of such practices.

One issue that is key to the application of the BVP procedures is that personnel administering the procedures must be trained in the RFP process for best value contracting for construction projects. (Minn. Stat. 16C.03, subd. 19 (2008)) (State of Minnesota, Office of the State Auditor). Many of the representatives from cities contacted expressed their frustration with not being able to define the level of training or to identify entities that can provide training.

The City of Roseville is one of the first cities in Minnesota to apply BVP procedures, with its skating rink. Staff received comprehensive training and consultation on the project from Arizona State University. ASU is one of the leading developers of BVP practices in the country, and offers one of the more comprehensive training certification programs in BVP.

The League of Minnesota Cities offers an informational seminar on BVP, but this does not constitute the training required by the new statute. So, does ASU's program satisfy the statute's training requirement? This remains unclear. Even though ASU has the most comprehensive and widely accepted BVP methods and training in the country, the training requirement from Minn. Stat. 16.03 is not clearly defined. This lack of a clear definition of what training will satisfy the requirements of the statute is a primary obstacle for cities considering adoption of BVP practices.

Another reason that cities have not adopted BVP practices is the lack of clarity on how BVP differs enough from their current system to warrant the extra training. The current procurement procedures already allow cities to consider factors other than price. The requirement that the bidder be "responsible" allows cities to protect themselves from the risk of unqualified bidders, particularly on the smaller, less complicated projects that make up the majority of procurements by cities and counties throughout Minnesota.

Until further research is done regarding these and other obstacles, and this research applied to updating the current legislation, rapid, widespread adoption of BVP by the cities and counties of Minnesota appears unlikely. Successes with the method, such as Roseville's skating rink and the University of Minnesota and MnDOT projects, indicate that this is a valid and useful method of procurement. These results also imply that further definition of the training and evaluation criteria through legislation would be valuable and would allow more cities and counties to adopt BVP practices on projects in the future.

Mr. Michael Michelsen, student team

## **Introduction**

By 2006, the City of Roseville was ready to replace major components in its skating center arena—the refrigeration system and the dasher boards (the thin plywood or plastic-surfaced boards that encompass a hockey or skating rink). The skating center is composed of three specialized areas: an indoor skating arena, an outdoor speed skating oval, and a banquet and meeting facility.

In 2007, authorization was obtained from the city council to hire a Canadian geothermal systems engineering firm, Geoexergy Systems Inc., to study the feasibility of installing a geothermal system in the skating center arena and tying it in with the skating oval and the entire city hall campus facility. The study was to consider the use of a geothermal system versus a conventional system. After extensive research, Geoexergy determined that it was in fact feasible to install a full geothermal system.

As a result of this study, a budget of \$1,013,000 was set up for a full geothermal system installation, and Karges-Faulconbridge, Inc. (KFI) was hired to design the system and complete a campus-wide master plan. A team of city officials (the RSC team), including the parks & recreation director, the public works director, and the park planner, regularly updated the city council with the study and budget estimates.

As the scope became clearer, KFI developed a revised budget of between \$1.5 and \$2.2 million, depending upon the alternates selected, for a geothermal refrigeration system with ground heat exchanger and new floor piping. The RSC team was charged with keeping the project within the approved budget, minimizing skating center operating down time, and maintaining what had always been an excellent skating facility.

Historically, the City of Roseville has used a design-bid-build project delivery system for its large projects and has selected the lowest responsive, responsible bidding contractor based on state law. Given the program requirements, it was the goal of the RSC team to select a high-performance contractor who had previous geothermal experience for ice arenas. It was during discussions with the city attorney that the RSC team discovered that a new law had been passed in 2007 that allowed for a best value procurement process whereby considerations other than price could be used to award the construction contract.

After extensive research, the RSC team contracted with Arizona State University (ASU) to receive training, oversight, and consulting services. Five individuals (two city staff members, a representative from KFI, and two city attorneys) went to ASU for a week of training.

## **Solicitation Phase**

Because of the unique nature of the project, the RSC team knew it wanted to select a contractor who had experience with geothermal systems for ice arenas. According to Lonnie Brokke, director of parks and recreation for the City of Roseville, “We were really concerned about [the fact] it was very limited in terms of contractors that were out there that could really do it, specifically for ice facilities. Geothermal was out there for a long time, but in ice facilities it was relatively new. We didn’t want to have to go to low bid. We want to be able to choose

somebody who has had a lot of experience, who has had a history [with geothermal on ice arenas]. We wanted to go through a process that got us to the best value considering best price, best experience, everything. So we started having a conversation with [our City Attorney] and I remember sitting there and saying 'I hope that we don't get Joe Schmoe down the street who has done house geothermal, who says, 'Boy, I could do an ice rink'.'" [1]

The RSC team was also concerned about the quality of its facility being compromised by a low-price bidder who had not built a geothermal system for an ice rink. According to Lonnie Brokke, "We were concerned about getting somebody who had experience to be able to do it. This is a facility built in 1969. [It's] probably the best ice sheet in the State of Minnesota. We don't want to lose any of [its] quality." [1]

The RSC team obtained assistance from the University of Minnesota in identifying which contractors should receive an RFP during the solicitation phase. When asked why participation by the University was so important, Duane Schwartz, public parks director for the City of Roseville, stated: "Their involvement with it [the solicitation phase] [was important] because we were able to capitalize on their experience with their contractors and their access to [contractor] experience ratings. It helped [to] get a bigger pool [of contractors]." [1]

In April 2008, a request for proposal (RFP) was prepared by the RSC team based upon the University of Minnesota RFP format and modified to meet the specifications of the project.

The RFP contained the following sections and information: [4]

- Overview of the RFP Process and General Instructions to Respondents

Schedule of Events

End Date	Task
04/01/08	RFP issued
04/10/08	Site walk/pre-bid meeting
04/15/08	Last day for questions
04/18/08	Proposals due
04/22/08	Shortlist
04/23/08	Interviews/Identify BV
04/24/08	Pre-award kickoff meeting
05/14/08	Pre-award meeting
05/19/08	City council meeting
05/20/08	Anticipated date of award

Evaluation Criteria (see below for a detailed explanation)

Category	Weight
Responsiveness	Pass/Fail
Cost	25%
Risk assessment and value added plan	25%
Interview	20%
Past performance information	15%
Schedule	15%

- Background/Scope of Work
  - In addition to listing performance requirements, in this section the City stated that “significant” credit would be given to firms that could
    - § Guarantee energy savings (the guarantee must identify the total amount of energy to be saved).
    - § State how the contractor knows it can save this amount (proof from past clients).
    - § State how the contractor will make measurements.
    - § What the contractor will do if it does not meet its measurements.
  - The total construction budget was listed at \$1,013,000.
  
- Structure and Content of Response—respondents would be evaluated based upon the following criteria:
  - Responsiveness—respondents had to prepare submissions that followed the format and sequence specified in the RFP, including completion of all attachments.
  - Proposal Information (40%)
    - § Schedule (15%)
      - substantial project duration in calendar days
      - total project duration in calendar days
    - § Cost (25%)—both base bid and alternates
  
- Risk Assessment and Value Added Plan (25%). Respondents had to submit a RAVA plan. The purpose of a RAVA plan is to determine whether a contractor can quickly calculate the risks on a future project in terms of cost, time, and client expectations (of quality and performance). It also lists any value or differential that it brings to the project in terms of costs, time, or quality.

- Past Performance Information (15%). Respondents had to send out survey questionnaires and provide references from past project clients. Performance information was also obtained from the University of Minnesota on all respondents.
- Interview (20%). The City could interview critical team members from each proposal firm, including its subcontractor firms.

In deciding who should receive the RFP, the RSC team queried the University of Minnesota, KFI, and Geoxergy for recommendations of contractors with prior geothermal experience on ice arenas. The project was publicly advertised and was made available at various plan exchanges. Two pre-proposal meetings were conducted with contractors who had been recommended. The meetings included a contractor education meeting conducted by ASU and a traditional pre-proposal walk-through conducted by ASU and the RSC team.

RFPs were not accepted from any contractors who did not attend both pre-proposal meetings. The City also had the option of short-listing firms prior to the interview phase if there were too many firms.

### **Qualification Phase**

After receiving completed RFPs from three of the five contractors who attended the pre-proposal meetings, the evaluation team began evaluating the RFPs. The Roseville evaluation team (RET) was made up of the following five individuals: the parks & recreation director, the public works director, the park planner, the RSC manager, the city attorney, and the city engineer.

The contractors had to submit to a series of interviews by the RET. The interview questions were originally prepared by ASU but were not strictly followed due to the unique aspects of the project. According to Lonnie Brokke, “They [the contractors] were all over budget from the start. So our interview questions veered a little bit away from the [ASU] questions and really focused on value engineering and understanding their proposal better...” [2] According to Duane Schwartz, “What we really did with [the interviews] is pick the brains as to how we can keep the project more in line with the budget...and talk to them about their ideas about how we can proceed with some...quality control issues that they could, if given the opportunity, cut costs. Again, we wanted to understand where their numbers were coming from, where their project was coming from, and then be able to really talk about all of the options that we have...” [2]

Scoring of the evaluation criteria used a scale of 1, 5, and 10.

- 10 was used if the response was above average.
- 1 was used if the response was below average.
- 5 was used if nothing stood out for the response.

All evaluations were done individually and provided without the name of the contractor. The evaluations were sealed in envelopes and sent directly to ASU for group scoring. ASU received the evaluations and entered the data, including the bid price, into its scoring system. ASU then returned a prioritized list of the respondents, without vendor names.

The prioritized list included

#	Criterion	Firm A	Firm B	Firm C
1	Cost	\$1,989,000	\$2,128,000	\$1,848,000 (*)
2	Substantial completion (days)	120	135	135
3	RAVA rating	5.8	3.4	8.6
4	Interview rating	5.0	4.7	7.0
5	Average PPI score (1-10)	9.8	9.9	9.5
6	Total number of PPI surveys	15	11	6
	Average computer ranking	55	48	99

(\*) Alternates ultimately increased cost to \$2,217,400.

Firm C was identified as the firm with the highest average computer ranking. Under the terms of the RFP

- If the highest ranked vendor is within the City budget and has the lowest cost, it will be invited to the pre-award period.
- If the highest ranked vendor is within 10% of the next highest ranked vendor's cost, it will be invited to the pre-award period.
- If the highest ranked vendor is above 10% of the next highest ranked vendor's cost, it will be invited to the pre-award period if dominant information justifies invitation.
- If the highest ranked vendor is not within the City budget, the City will proceed to the highest- ranked vendor within the budget using the same procedures as above.
- If all vendors are over budget, the City could reject all proposals or proceed with the lowest proposal by obtaining additional funds.

In this case, each of the responding firms had bid prices that exceeded the City budget of \$1,013,000. Therefore, the potential best value vendor was identified as Firm C, with the lowest price of \$1,848,000, excluding alternates.

During the pre-award period, the potential best value vendor was required to [4]

- Clarify any issues or risks.
- Prepare a quality control document.
- Not modify its cost, project durations, or project team.
- Accept and mitigate all risks as identified by itself and other respondents.
- Conduct a pre-award meeting, after which the City may
  - Issue an award and a notice to proceed
  - Consider another respondent for potential award.

The pre-award phase was stretched out in order to adequately address all the value engineering issues, quality control plan, and quality assurance process. There were three pre-award



meetings focusing on some of the costs and value engineering. The selected contractor, Harty Mechanical, was encouraged to take some of the ideas from the other contractors and bring them to the table. According to Duane Schwartz, “Every kind of idea came and they were sorted and flushed out through those pre-award meetings. Our engineering firm [Karges-Faulconbridge] was also critical and extremely involved because they had to approve any changes that may occur. So they were very involved in the pre-award phase, reviewing any suggestions that [were approved]. So the entire design team was [involved].” [2]

## **Transparency and Neutrality**

Transparency and neutrality were achieved by the City in the following ways:

- The best value procurement process was clearly defined in the RFP.
- The RFP had been based upon a University of Minnesota format that had been used extensively.
- Proposals, past performance information, and references were sent directly to ASU by the vendors and references for purging of vendor names before being returned to the RET.
- Evaluations of the vendor proposals and interviews were prepared separately by the members of the RET and sent directly to ASU for tabulation.
- Final results were communicated by ASU to the RET without vendor names.
- The decision to use best value procurement was made in an open and consultative environment.
  - City council meetings during which the process and results were discussed were open to the public and televised.
  - News releases were issued before, during, and after the award.
  - Various advisory groups were consulted about the process.
- Vendor scores were made available upon request after the award. No vendors requested their scores.

The qualities of transparency and neutrality were deliberately sought by the City when it sought out the professional advice and services provided by a group located at the University of Arizona called the Performance Based Studies Research Group (PBSRG). All of the training and much of the routine data handling was done by this group. According to Duane Schwartz, “They [PBSRG] were involved a lot during the training. [John Savicky] helped us along with the surveys and scoring. They took bids and gave us a spreadsheet of the numbers, and since it’s started, we’re doing our weekly meeting logging through [PBSRG].” [1] According to Lonnie Brokke, “I think that the process has been, in terms of transparency, a definite process so even if somebody were to come in and question [us], it would be easy to come in and pull out a file and [say] here is the process. There is nothing to hold back. Here it is. I think that they would see that once we laid it out.” [2]

## **Delivery Methods**

Historically, the City had used the design-bid-build (D-B-B) delivery method. Up until 2007, the City legally had to use the lowest responsive, responsible bidder on all contracts that exceeded \$50,000. This project used the D-B-B delivery method from the startup to the pre-award period.

During the pre-award period, the City began to hold meetings with the identified best value contractor (Harty Mechanical) to discuss value engineering proposals, with the hope of reducing the overall cost of the project. The value engineering proposals allowed the City, the contractor (Harty), and architect/engineer (KFI) to make changes to the plans and specifications that would

reduce the cost. During the value engineering discussions, the delivery method resembled a design-build (D-B) process. The contractor (Harty) worked closely with the City to arrive at an acceptable budget, and the architect/engineer, KFI, acted in an advisory role while continuing to work for the City, not for the contractor.

The manner in which the contractor (Harty) took the lead in offering value engineering ideas (thereby reducing the project cost to an acceptable level prior to the contract award and becoming, in effect, a quasi-design-build contractor without a formal change in the contractual relationships) exemplifies the flexibility and adaptability of the best value procurement method.

## Risks

Risk on the project was minimized/managed through the following:

- The RSC team had spent several years developing a master plan for the project.
- The RSC team had hired consultants specializing in geothermal systems to study and prepare detailed plans and specifications.
- The RSC Team received extensive training before the procurement process began from the premier best value procurement training facility, PBSRG.
- Representatives from PBSRG continued to advise and consult with the RSC team throughout the project.
- The RCS team received advice and vendor references from a local proponent of the best value procurement process, the University of Minnesota.
- Each contractor was required to submit a risk assessment/value added (RAVA) plan as a part of its proposal. The RAVA plan required that each respondent [4]
  - List and prioritize major risk items that were unique to the project including items that may cause the project to
    - § Not be completed on time (schedule).
    - § Not finish within budget (cost).
    - § Generate change orders (change/scope management).
    - § Possibly be a source of dissatisfaction for the owner.
  - Explain in non-technical terms how the builder will avoid/minimize the risk.
  - Propose any options that could increase the value (expectation or quality) of its work.
- The RAVA plan for each of the respondents became a part of the contract for the potential best value vendor.
- The RCS team had an extensive pre-award phase during which it could plan and coordinate the project with the potential best value vendor. The pre-award phase provided the vendor with “a final opportunity to protect itself by allowing the vendor to carefully pre-plan the project before an award is made.” [4]
- As stated in Attachment H of the RFP, “In many cases, one of the vendor’s biggest risks (in terms of delivering on-time and with no change orders) is the client or an outside party. Therefore, it is in the vendor’s best interest to identify any issues or concerns ahead of time during the pre-award period. The vendor should minimize their risk by creating documentation that puts them in control and eliminates any outside interference that could hinder them from performing.” [10]
- Some of the tasks suggested in the RFP were [4]
  - Revisiting the site to do additional investigations
  - Identifying any concerns that all parties to the project may have and determining solutions to their concerns
  - Identifying project risks and how those risks can be minimized

- Identifying actions required by the client or client’s representatives
- As part of the pre-award phase, the best value vendor was also required to prepare a quality control document. This QC document had to include [4]
  - A complete project schedule with a breakdown of all major project activities and all significant activities that required action by the client or outside agencies
  - A list of client action items
  - A list of all risks identified in the RAVA plan
  - A list of factors that were outside of the vendor’s control
- Throughout the duration of the project, the best value vendor was required to submit to the owner’s representative a weekly report. This report was a companion to the QC document. Its purpose was to “document any issues/risks that affect time, money, or satisfaction.” The RFP further described the weekly reporting system as a method that “ultimately protects a high performing vendor by allowing it a mechanism to document all client decisions or actions.” [4]

## **Schedule**

The project had specific scheduling requirements. The deadline for opening the ice arena was October 1, 2008. As part of its quality control plan, a subcomponent of the RAVA plan on which the respondents were evaluated, the vendor prepared a detailed list and schedule of client action items. What made the best value procurement process rewarding was that the City could be flexible (negotiate) on its other schedule constraints as long as the major milestones (e.g. ice arena opening) that were identified during the pre-award phase were reached.

The pre-construction portion of the project took longer than anticipated due to the extended programming, design, training, and best value procurement process. However, the time and effort invested into the pre-construction phase allowed the construction phase to proceed more smoothly because each of the major project stakeholders understood its roles and responsibilities as defined and agreed to during the best value procurement process.

## **Scope Management**

The City’s responsibility in the best value procurement methodology was to identify the overall performance specifications (i.e. desired outcomes) in the beginning. The City made sure early on that the architect/engineer and the contractor understood the desired outcomes.

The evolution of the project delivery method from D-B-B to quasi-D-B and development of the RAVA plan allowed the contractor to help define, negotiate, and document (i.e. “own”) the project scope. By “owning the scope,” the contractor can avoid schedule disruptions.

The best value procurement methodology allowed the City to step back from managing the technical aspects of the project and allowed the contractor to manage them.

## **Time/Cost Relationship**

There appears to be a positive relationship between the amount of time that the City spent in pre-award preparation and the amount of time spent post-award by the City staff with project details and micromanaging the contractor. The more time that an owner can spend early on in understanding, communicating, and applying the underlying principles behind the best value procurement process, the more value (i.e. cost optimization) it will realize in reduced staff project management, fewer change orders and schedule disruptions, and ultimate satisfaction.

From the contractor's prospective, a great deal of time was spent at the beginning of the project, especially when preparing the quality control plan based upon the risk analysis that was prepared by Harty and the other contractors. However, by spending more time in the beginning identifying potential problems and how they could be resolved, less time was spent dealing with them when they did happen. According to Pat Harty of Harty Mechanical, "There were two or three [major problems] that were in the plan that came up and were taken care of. To go through and find out every single problem, you are never going to do that. If you can minimize that 25% to 50%, you are ahead of the game." [3]

### **Change Management**

Through the use of the quality control plan and weekly reports, the best value contractor was able to document any issues or risks that affected time, cost, or customer satisfaction. The use of the quality control plan and weekly reports also protected the contractor from the historic source of project changes, the client or owner.

By having the contractor "own the scope" through the RAVA plan, the City was able to avoid being asked to adjudicate and assign responsibility for scope conflicts (i.e. potential change issues) to either the contractor or the design/engineering firm.

The combination of 1) the requirement in the RFP for the contractor to closely analyze the project when preparing a RAVA and quality control plan, 2) the emphasis that owner put on the need to control the project costs and schedule in the best value evaluation process, 3) the close working relationship that the owner and contractor developed during the value engineering process, and 4) the owner evaluation of the contractor at the end of the project influenced Harty to minimize change orders on the project. According to Patrick Harty, "We are in the process together. [The way that] I looked at it was if it was in the QC plan, if it was something minor, we could work with that. The minor problems really weren't that big a deal. [Under] a conventional [D/B/B] process, money is so tight. You are on one side of the table and the owner and the architect/engineer are on the other. Everyone is fighting for every dollar that they can get their hands on because, essentially, if you are the low contractor you either made a mistake or you missed something. In this process, nothing got missed. There were no mistakes. It was completely different. On the opposite end [the conventional process] we would have brought [changes] up. We would have stopped work and said [that] we were not doing anything until the engineer and architect answered all of [our] questions and referenced how we were to take care of them. We were partners on the project. And we needed to get it done so that they [the City] were happy and we were happy. It's a good process and a great value for the City and for contractors." [3]

### **Separation of Responsible Parties**

From a purely legal standpoint, the relationship of the responsible parties did not change as a result of the best value procurement process. The City retained KFI and Geoexergy Systems early on in the project. That contractual relationship did not change when Harty Mechanical was selected as the best value vendor.

The best value procurement process allowed the practical/working relationship of the parties to become more fluid. Through the RAVA plan and weekly reporting system, Harty became responsible for managing both the City and its consultants. In turn, the City and its consultants effectively agreed to be managed by Harty.

## Post-Completion Evaluation

One of the major reasons that the best value procurement process can have a positive influence on the success of a project has to do with the owner evaluation of the contractor's performance after the project is completed. The effect that a positive evaluation can have on the contractor's ability to obtain future work will be the driving force for it to do quality work on schedule and within budget on the current project. According to Patrick Harty, "The biggest thing is that grade at the end. It helps our company with the best value process because we can look at it and say that we have experience with these systems, we have a history doing them and this is what we want our business to move forward in. To have [the City of] Roseville help back us...that we did a great job for them and we walked hand in hand during the process is the biggest difference."  
[3]

## Sources

[1] Interview with Lonnie Brokke, Jeff Evenson, and Duane Schwartz, October 1, 2008

[2] Interview with Lonnie Brokke, Jeff Evenson and Duane Schwartz, October 6, 2008

[3] Interview with Patrick Harty, November 6, 2008

[4] City of Roseville Request for Proposal, April 1, 2008

[5] City of Roseville, Interview Questions

[6] City of Roseville, Weekly Report

[7] City of Roseville, Value Analysis

[8] City of Roseville, RAVA Plan Rating Sheet

[9] City of Roseville, Quality Control Plan

[10] City of Roseville, Attachments

Mr. Michael Michelsen, student team

## Introduction

Historically, the City of Eagan had used the bidder qualification process for five years without being challenged. The bidder qualification process evaluated and graded a contractor's quality and experience against specific performance criteria. If the bidder achieved a minimum rating or score, it was allowed to bid on the project. The low-bid contractor was then awarded the project. The City believed that the bidder qualification specifications represented a fairly low standard for contractors to meet. Even after a contractor met the minimum rating, the City still struggled with it to get a good product. The City was required at times to assign internal staff to manage the contractor. It also experienced a large number of change orders.

The City felt that it was getting a more expensive project, long term. According to Russ Matthys, city engineer, "We had one contractor that we really had a lot of problems with and they were low bid on a least one contract every year. And it didn't matter, we as many times as we would yell at them or have discussions with them they just didn't seem to get it. They continued to bid on our contracts." [1]

City officials believed that it would be worth a little more money to get a quality project. According to Russ Matthys, "Eagan wants a quality product as much as anybody else. So it's sometimes worth paying a little more for that. We are willing to do that if it's going to be worth the benefit. There are a lot of people who could meet our bidder qualification specifications. It's a fairly low standard, and yet, we still may struggle with them to get a good product. You still may end up dealing with a lot of change orders. So even though they are the lowest qualified bidder, you still may get a more expensive project long-term just because of the struggles, changes orders and stuff like that." [1]

City officials wanted to evaluate contractors on a combination of their qualifications and price. According to John Gorder, assistant city engineer, "The best value takes more into scoring the contractor itself. It's not just price alone." [1]

For the Eagan city officials, the best value procurement process was the next logical step from the qualified bidder process, so in 2008, the City of Eagan proposed using the best value process on two street overlay projects totaling 16 miles (08-03 and 08-04) on local and collector streets in the city. The City chose to use the best value procurement process because the two projects had a direct effect on a large number of city residents. According to John Gorder, "The street improvements project that we used [best value procurement process] on is mainly in residential areas. Therefore, the project affects the public to a large extent. Whereas most years we do eight (8) neighborhoods, here we were doing fifteen (15) neighborhoods. If you get a contractor that can't control the schedule and the work product and, somewhat, the public relations by doing a good project, by performing well on the project, it looks bad for the City. It's a PR issue." [1] According to the advertisement for bids, both projects were "extensive, involving many affected property owners. Timing of the project is critical for the safety of the general public and to minimize disruption. In addition, the City has limited financial resources to commit to the project(s). Accordingly, the project(s) must be accomplished with a minimum of interruption, on time, and without cost overruns." [1]

## Solicitation Phase

With the best value procurement process, the City wanted to select the best contractor for the price it wanted to pay and to possibly filter out any contractors that the City had poor experience with in the past. According to Russ Matthys, “I think that we were going to be able to truly get the best bang for our buck. The bidder qualification allowed us to get a good contractor. That was important. We wanted to be able to have a good contractor with a proven record. With the best value we felt that we were able to get the best contractor for the price that we wanted to pay. In my mind there is a difference. With the bidder qualifications we may have to take a good contractor who has a lower bid than a high quality contractor whose bid is higher.” [1]

The best value procurement process was based upon the City’s previous bidder qualification process. The qualification criteria were converted to best value by assigning relative weights or points to each for the evaluation criteria. The bid price was then included as part of the formula for determining an adjusted score. The City was advised by the city attorney to not include two bidder qualification evaluation criteria in the best value criteria. The criteria were 1) the contractor’s history of initiating change orders and 2) the contractor’s history of complaints regarding completion deadlines or the quality of its work.

The evaluation criteria weights or points were assigned by the City based upon a subjective determination of which criteria would be the best predictor for good project results. It was also the City’s intent to extend the solicitation to as wide a group of qualified contractors as possible. According to Russ Matthys, “We realized that there are good qualified contractors that haven’t worked in Eagan. We didn’t want to exclude anyone. If you look at it, we go 40 [points] and 40 for experience and performance of the contractor [with] similar projects and then the supervising folks. Those are the two important components of it.” [1]

Unfortunately, the City proceeded with the best value process with little or no prior experience, expertise, or training. According to Russ Matthys, “I felt that with the information that we had [received] from the League of Minnesota Cities, the door was open enough for us to do it and that it was worth taking a shot. Our intention [was] to become certified, because that is a requirement. As of right now the certification language is pretty gray. If we got called on any of the bids, that part would have been our weakest area to stand on.” [1]

In March 2008, the City issued an advertisement for bids using its newspaper of record, *Eagan This Week*, and *Construction Bulletin*. Complete digital contract bidding documents were made available using Qwest Internet CDN. The technical proposal included the following sections and information: [2]

- Background information on the company
- Experience/performance on previous projects of the contractor and of the assigned superintendent and foreman; and the major equipment available for this project.

Selection factors—two factors were to be considered in the contractor selection process: [2]

- Price—the bidder’s overall low based bid
- Performance—the bidder’s performance was to be evaluated in the following areas:
  - Experience/past performance of constructing similar projects for other agencies within the last five years (25%)
  - Experience/past performance of constructing similar projects in Eagan within the last five years (15%)

- Experience/past performance of key personnel constructing similar projects for other agencies within the last five years (25%)
- Experience/past performance of key personnel constructing similar projects in Eagan within the last five years (15%)
- Availability of major equipment to complete this work in a satisfactory manner (20%)

Pre-bid conference—attendance at a mandatory pre-bid conference was required. The purpose of the conference was to provide details and answer questions regarding the evaluation/selection criteria that were to be used, along with bid price, to select a contractor for contract award under the best value contracting authority. Failure to attend this meeting eliminated the absent bidder’s bid submission from contract award consideration.

**Qualification Phase**

An aggregate average technical evaluation score of the bidder’s performance was to be determined by the five-person technical evaluation committee [2] consisting of the city engineer, the assistant city engineer, the transportation engineer, and two project coordinators.

The contractors had to submit references from prior projects. These references were contacted, and the responses were scored using the scale below. These scores were included in the experience and performance criteria categories. No interviews of the bidders were conducted by the evaluation committee.

Each portion of the technical score was to be evaluated on the basis of the following scale: [2]

- Excellent = 90% to 100% of maximum points (best in industry)
- Good = 80% to 90% (efficient and effective)
- Fair = 70% to 80% (more than adequate)
- Acceptable = 50% to 70% (adequate)
- Unacceptable = less than 50% (less than adequate)

The rating scale was used to give the evaluation committee members additional latitude in giving points to a contractor. Members of the evaluation committee knew the identities and bid prices for each of the bidders.

Contract Award Selection—the City awarded a contract to the bidder whose bid price, quality, and experience best conformed to the overall interests of the City, based on the lowest adjusted score. The formula used in the contractor selection process to determine the bidder’s adjusted score was the bidder’s base bid divided by the bidder’s aggregate average technical score, determined by the technical evaluation committee, as follows: [2]

$$\frac{\text{Low Base Bid}}{\text{Total Aggregate Technical Score}} = \text{Adjusted Score}$$



Computations of the adjusted score were prepared by a member of the evaluation committee.

The results of the two bids were as follows:

**Contract 08-03 [3]**

<b>Contractors</b>	<b>Total Base Bid</b>	<b>Technical Score</b>	<b>Adjusted Score</b>
1	\$1,368,882	92.95	14,727
2	\$1,446,658	95.45	15,156
3	\$1,423,574	91.40	15,575
4	\$1,660,461	74.40	22,318

**Contract 08-04 [4]**

<b>Contractors</b>	<b>Total Base Bid</b>	<b>Technical Score</b>	<b>Adjusted Score</b>
1	\$1,919,804	95.45	20,113
2	\$1,937,619	92.95	20,845
3	\$2,091,021	91.40	22,877
4	\$2,181,383	73.30	29,760
5	\$2,243,883	74.40	30,160

In both contracts, the low bidder was also the best value contractor.

**Transparency and Neutrality**

Transparency and neutrality were compromised by the City of Eagan by the manner in which its best value procurement process was implemented. Computations of the technical evaluations were performed internally by the City. No independent third party reviewed the results for accuracy. Both the contractor names and bid prices were known to members of the evaluation committee. Few external resources were used to evaluate the best value process. The process was primarily based upon the bidder qualification process previously used by the City. Any inherent flaws in the previous system invariably carried over to the new system. Neutrality in the process could not be determined because under both contracts the low bidder was also identified as the best value contractor. It is, therefore, difficult to determine the extent to which the evaluation process was ultimately responsible for determining the best value contractor.

**Delivery Methods**

It could not be determined if the delivery method had an effect on the best value process. The City had used the D-B-B delivery method for previous projects and did the same with the two best value projects.

## **Risks**

Virtually no training in the best value procurement method was obtained prior to initiating the process, which could have been an inherent risk to the City. (The lack of adequate transparency and neutrality can be a source of disputes by unsuccessful contractors.) There was virtually no risk identification or evaluation by either the City or contractors prior to awarding the contract. Therefore, the risk of disputes between the owner and contractor appears to have remained unchanged.

The primary benefit to using the best value process is that previous experience and the evaluations from owners on similar projects can be used to evaluate and predict a contractor's performance on the best value projects. Under the bidder qualification process, only the bid price can be used to select a contractor once a qualification threshold is reached.

Use of the best value process did attract higher quality contractors than under the bidder qualification process. By inference, the higher quality contractors should have helped to minimize financial or project disruption risks to the owner.

## **Schedule**

Use of the best value process does not appear to have affected the schedule for the projects. The contractor's commitment to maintaining the schedule does not appear to have been changed by using this process.

## **Scope Management**

Because risk identification or evaluation was not performed by the contractor, it did not "own the scope" of the best value project. Therefore, there was no effective change in scope management for the best value projects versus other traditional bid projects. The City therefore had to rely upon the inherent scope management capabilities of the best value contractor's internal systems and personnel. The contractor was also not protected from the traditional source of scope changes--the client or owner.

## **Time/Cost Relationship**

There does not appear to have been a relationship between the amount of time that the City spent in pre-award preparations and the amount of time spent post-award by the City staff with project details and managing the contractor other than that previous low bid contractors who required an inordinate amount of City staff time were discouraged from bidding on these projects.

## **Change Management**

No quality control plan or weekly reports were required by the City. As a result, there was no documentation of issues or risks that affected time, cost, or quality. Therefore, there were no apparent changes in the manner in which changes were identified and managed. The City had to rely upon the inherent change management capabilities of the best value contractor's internal systems and personnel. The contractor was also not protected from the traditional source of changes, the client or owner.

## **Separation of Responsible Parties**

The City uses on-site engineering professionals on all projects. There was no change in the contractual relationship between the City and the contractor from using the best value procurement method. Because the risk for dispute between the owner and contractor remained unchanged, it was important that a clear separation of the responsible parties be maintained.

### **Sources**

[1] Interview with Russ Matthys and John Gorder, October 23, 2008.

[2] City of Eagan Specifications, City Contract # 08-04.

[3] Bid Summary—City Contract #08-03.

[4] Bid Summary—City Contract #08-04.

Mr. Ross Hoeffner and Mr. Will Schultek, student team

### Introduction

In July 2005, Regions Hospital, a private institution owned and managed by HealthPartners, began seeking design and construction services for a large expansion project for its campus in downtown St. Paul, Minnesota. Valued at approximately \$179 million, this expansion focuses on key areas of the hospital's practice such as surgery, cardiology, general medicine, and behavioral health. The following project facts were pulled from the fact sheet included in the Regions Hospital Expansion 2009 press kit:

- Total of 385,000 square feet in new construction (about 72,000 SF of which is "shelled" for completion in future years, 2009-2013)
- 62,000 square feet in renovation
- 55,000 square feet for Emergency Center expansion
- New patient bed tower to include five floors of patient care units. Each floor will include 36 private patient rooms
- 20 new operating rooms
- 430-stall underground ramp for patients and guests at the base of the new tower addition
- 950-stall ramp for employees on University Avenue between Robert and Jackson Streets

The large size and complexity of this project prompted Regions Hospital to seek out an owner's representative to lead the firm through the process.

Although Regions Hospital is considered a quasi-public entity, it is important to note that decisions made concerning this project were not subject to public policy.

### Application of Best Value Procurement

The decision to move away from traditional construction methods stemmed from several issues:

- Large capital investment requirement
- Complexity—experience required, i.e., most proven qualified candidate
- Critical operations concerns—hospital operations must not be disturbed during construction

Because of these issues, a BVP method was used for *both* designer and contractor selection. The project was complex: an addition to an existing hospital which must remain open during construction. The owners wanted a team with experience in hospital construction and knowledge of how to handle issues which might arise from building over an operational hospital. In addition, the owner wanted to bring the contractor on board early to help with estimating the project and to establish a GMP early into the pre-planning process.

When both designer and contractor had been selected, they were asked to submit their fees for consideration. Neither party had a firm idea what the overall construction budget would be, but Regions employed its expertise in developing the best total project within its budget. The fee structure was to be adjusted accordingly once the GMP was determined.

## Solicitation

Regions Hospital chose to include base location and experience as pre-qualifiers. It wanted a locally based design firm to ensure easier communication for all parties. It also placed value on prior experience, so short-listed all design firms that had experience with multiple large health care facilities.

In the request for proposal the following criteria were established:

- Team experience—20%
  - The level of experience that the design firm brings to the project
- Personnel strength—20%
  - Evaluation of team members
- Project understanding—20%
  - Does this firm understand the goals and objectives of Regions Hospital's expansion plan?
- Schedule understanding and approach—20%
  - How well does this team understand the specific constraints and challenges of building a new addition onto an existing hospital?
- Differential advantage—20%
  - What aspects were brought forth outside the scope of the RFP in terms of risk, safety plans, etc.?
- Fees—20%
  - Fee structure based around initial construction budget and scope of work

The contractor's primary pre-qualification requirements were experience with large-scale hospital construction and the proven ability to coordinate construction operations while the hospital remains open for business.

The contractor's request for proposal was similar to the designer's RFP but focused on the construction aspects of the project.

## Qualification

During designer selection, three firms were asked to submit concept proposals. Evaluation was completed using the grading basis provided in the RFP.

- Team experience—20%
- Personnel strength—20%
- Project understanding—20%
- Schedule understanding and approach—20%
- Differential advantage—20%
- Fees—20%

Two firms were then asked to submit more detailed proposals, including development of a design concept. One firm was selected, and the other was given a \$25,000 stipend for its design work. Re-evaluation of these proposals was completed to select the final designer.

Three contractors were asked to submit concept proposals. Their evaluation was completed using the grading basis provided in the RFP.

- Team experience—20%
- Personnel strength—20%
- Project understanding—20%
- Schedule understanding and approach—15%
- Differential advantage—10%
- Fees—15%

### **Transparency and Neutrality**

Because Regions Hospital is a non-governmental agency, it was able to operate outside of the statutory requirements that require government agencies to disclose their selection criteria. The needed transparency was achieved between the selection committee and the hospital's board of directors.

### **Delivery Methods**

The contract was awarded under a guaranteed maximum price (GMP) to a construction manager at risk during the design phase. The contractors were asked to submit their philosophy of GMP to the selection board including

- Experience with GMP contracts
- Contingency percentage typically used in GMP contracts based on design development documents for similar projects
- Methodology for return savings and unused contingency back to the owner
- Shared savings philosophy

The hospital chose to award all work normally assigned through an annual contract to the contractor for the hospital expansion project.

### **Risk**

Construction was to take place during hospital hours, so it was very important to the owners that any contractor who was awarded this project had prior experience and a plan of action to mitigate any issues with daily hospital operations that might come forth during the project. This "extra" serves as a point of value to the owner that might not be taken into account in a low-bid situation.

The hospital caregivers and administration were the largest risk to the budget for the project. A "best care/best experience" ethic was an ongoing improvement initiative within the hospital during the design and construction process. It was determined that in order to approve an owner-directed change, the hospital staff must first present their proposed changes to their supervisors. If the proposed change was deemed valid, they would present the change to the owner's representative, director of facility planning, and a member of the senior leadership team for the change to be approved, priced, and also to see if it could be accomplished.

## **Schedule**

The contractor was brought on board early in the project and was therefore able to order long-lead items to ensure their proper delivery date.

The contractor was able to provide a detailed plan of activities to allow for the most efficient construction work. Pre-planning was also used to determine more accurate dates for shutdown of hospital sections and where temporary access should be assigned.

## **Scope Management**

In order to effectively manage the scope, the general contractor was brought on the project during schematic design to offer estimating services and expertise. This allowed the contractor to help the hospital stay within the budget it planned.

Nearly all of the scope changes brought forth in the project thus far have stemmed from the owner. Under the GMP, the overall change order process has been a “give and take” relationship between the parties. As the project has progressed, the general contractor has released funds, which have then been reinvested back into the expansion project. These change orders are monitored and checked by the owner’s representative to ensure the prices quoted are within the range of fair market price.

## **Time/Cost Relationship**

Overall schedule did not drive project decisions. Current hospital operations were the top priority along with quality construction. Pre-bid planning had no effect on the time/cost relationship.

## **Change Management**

Extensive pre-planning allowed proper review of construction documents, which is thought to reduce the impact of changes during the project. Changes and issues are less costly, in terms of time and dollars, when made early in the project.

With changes coming from the owner, it is important that someone is looking out for the owner’s interests, especially in a GMP contract. Without a third party to review and monitor changes, the chance an owner may be taken advantage of is greatly increased.

Effective communication techniques were stressed early in the project by the owner’s representative. As issues were brought forth during the project, the owner’s representative made sure to bring in all parties to air out problems and come up with solutions. This process helped the collaborative team be more efficient in problem-solving.

## Separation of Responsible Parties

### Contractual Relationships

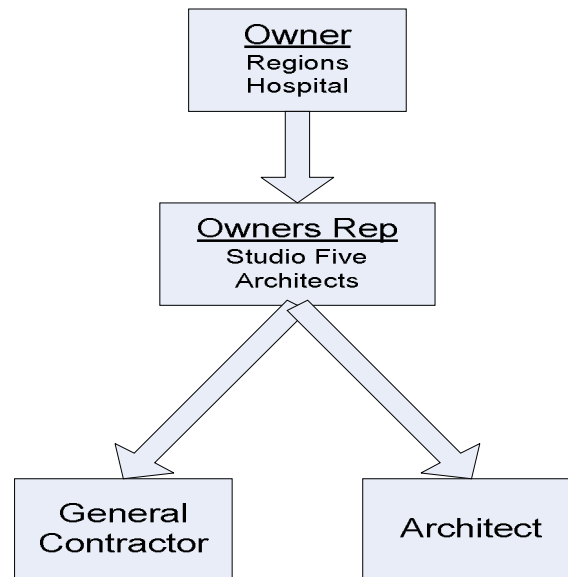

Though there are separate contracts with the contractor and the architect, a collaborative process has been employed, which has given the architect and general contractor open-door communication throughout the project. The owner's representative feels that whenever something needs to be discussed, the owner, architect, and general contractor should be present. This eliminates the back-and-forth bickering sometimes found on projects.

### Works Cited

Regions Hospital Expansion 2009. Regions Hospital. Sept. 4, 2008

<http://www.healthpartnersmarketing.com/regionsexpansion/>

Reichter, Barb, and Linda McCracken-Hunt. "BVP- Regions Hospital."

personal interview. Oct. 8, 2008.



Mr. Adam Bakeman and Ms. Angie Myrechuck, student team

**Introduction**

The Minnesota Twins baseball stadium, Target Field, is being constructed in the warehouse district of downtown Minneapolis. Multiple agencies are in charge of construction and choosing how to spend money, public and private. Ed Hunter is the representative for the Ballpark Authority (BPA), which has been given the responsibility of making decisions when public funding is involved. Dan Mehls is the project manager with Mortenson Construction in charge of building the ballpark, and Dick Strassburg is the owner’s representative for the Minnesota Twins.

The ballpark will be completed in 2010 and has a total construction budget of around \$521 million: \$390 for the stadium, of which \$350 million will be publicly funded; and \$105 million for the infrastructure, of which \$90 million will be public.

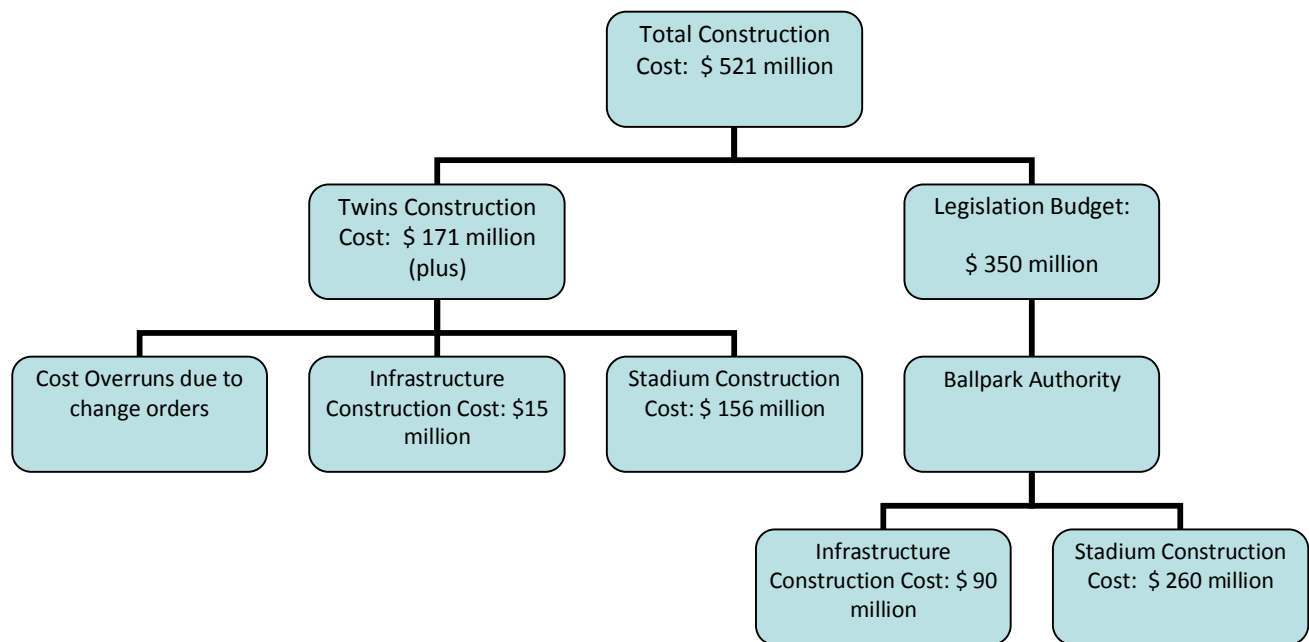

The Minnesota legislature granted the use of best value to the Ballpark Authority/Mortenson/Twins in an attempt to get a quality product in the time needed and at the best cost to the taxpayers. It specified that in the event best value is used, the Ballpark Authority must provide written explanations as to why it felt the more expensive option was a better use of taxpayer money than the low bid. This document would then become the legal reasoning for the use of best value in any circumstances where the awarding of the contract is being contested.

Best value is being used selectively throughout the ballpark, and discretion concerning the use of BVP is left up to the Ballpark Authority, Mortenson, and Dick Strassburg. BVP was used in multiple ways for the ballpark, such as the selection of the construction manager (Mortenson), the masonry and concrete placement (also Mortenson), the playing field grass, the scoreboard, seating, and mechanical and electrical.

The majority opinion from those interviewed is that BVP offers a large reduction in risk incurred by all the major parties including the owner, architect, CM, engineers, subs, etc. They thought BVP is an excellent way to

- Make sure the process is properly understood by the subs prior to bidding.
- Confirm that participants are capable of their responsibilities even if they initially qualify.
- Determine good past records on similar projects.
- Check for/include SWMBE (small, women, and minority-owned business enterprise).
- Assess current workloads, and whether participants can handle the project.

BVP is also considered to be a time (schedule) saving device. By having the best contractor and making sure the risks are fully understood and planned for, most problems can be avoided, even though BVP takes longer on the front end due to

- Interviewing potential subcontractors
- Allowing time for subcontractor rebid/assessment
- Evaluating and scoring each potential subcontractor
- Selecting a subcontractor
- Documenting why the BVP was used in each case

In the planning and letting phase, the overall process makes up for this increase in time by having much less time spent in discussions of scope changes and change orders. The process used in the BVP for the ballpark was one that is commonly used for BVP by other agencies:

- Begin with putting out a request for qualifications that contractors can reply to.
- When the qualifications are reviewed, select contractors are sent bidding information. They review the plans and specs (which may or may not be complete). They then put their bids in and await further notification.
- A selected panel for the project then interviews each bidder; this interview is to make sure the bidders
  - Understand the full scope of work
  - Can handle the work load
  - Have a good past history
  - Participate in SWMBE
  - Have included all their materials
  - Can change their bid price if they need to
  - Understand the BVP process
  - Have submitted all the forms needed
- Contractors are then allowed to make any revisions to their bids based on any new information they gathered during the interview meeting, and then resubmit their bids.

- Final decisions on subcontractors are based upon the pricing bid first. If it is felt lowest bid is the most responsible bidder, then the award will go to that bidder. If the reviewing council does not feel the lowest bidder is capable of completing the job, it can move on to the next lowest-priced responsible bidder.

## **Solicitation**

Under private contracts through Mortenson, the solicitations of the major contracts that were bid through the best value procurement method were in the form of a request for qualifications that any contractor could respond to. Qualifications sought included experience, record of success on similarly sized projects, qualifications of individuals within the firm, safety record, and ingenuity. A committee would then decide, based on how the contractor fulfilled these qualifications, which contractors would be sent bidding information. Included in the instruction to bidders was an explanation that best value procurement would be used in the selection of contractors. The bidders were informed of the criteria they would be judged on and how the criteria would be weighted. For example, cost could be 50% of the score, MBE/DBE participation could be 15%, history of working on projects of this scope could be 15%, and current workload yet another portion of the score. Based on the initial bids, the top contractors in qualifications and price were invited to an interview to review their bids to be sure it was understood why the bids were priced as they were. The scope of the work was reviewed and the contractors were then allowed to re-calculate their estimate. This is an example of how the use of best value procurement allows for a reduction in risk for both the contractors and the subcontractors.

## **Qualification—Pre-bid**

A comprehensive list of qualifications for contracts considered for BVP included the following:

- Price
- Personnel experience and qualifications
- Relevant experience
- Record of completing projects of this size
- Safety record
- MBE/WBE participation
- Understanding of the project
- Schedule

The committee looked at the firm as a whole to decide whether its workforce was capable of completing the task of the contract and had the necessary certifications. The firm needed to show experience on projects of this size and provide its record of completing projects on time and within budget. A specific MBE/WBE participation was important because of the public funding being supplied to the project. The committee was willing to pay more for a contract that would fulfill this need. Safety was also important. If a contractor was missing any one of these criteria, it was typically eliminated from consideration, or a higher contingency was placed on its contract (although that did not usually happen.) Cost was commonly weighted higher than any of the other criteria. Typically, the low bid contract won.

Another consideration when qualifying contractors is whether the project is fast-tracked and design will not be complete during the bidding process. The contractors who Mortenson knew had a history of making numerous change orders wouldn't be considered as strongly as those who would be able to offer a smoother construction process and still deliver the contract.

Other considerations when selecting a contractor were

- Does it have the capacity to deliver?
- How is it staffed?
- What are its capabilities?
- What other projects does it have?
- Can it perform at this scale?

When looking at those questions, it became clear some contractors would have problems keeping up to the schedule.

### **Transparency and Neutrality**

In bid selection, the Regions team often tried to adhere to public bidding procedures. Ballpark legislation, however, specified that in cases where the construction manager identified issues of scheduling or availability of materials, contract “negotiations” would be allowed. The manager must closely document reasons for that decision to enable it to stand up to public scrutiny. The contractors bidding on the work were given a list of criteria they would be graded on. They were not supplied with the weights with which the criteria would be graded. The names of the graders of the best value contracts were also supplied in the instructions to bidders. The final scores of contractors were not released; the evaluations were “closed,” but the Ballpark Authority was open to discussing the results with the contractor and the reason for its not getting the contract, if the contractor asked.

Individuals from all involved entities weighed in on the grading process in order to keep the committee as neutral as possible. The team included seasoned Mortenson project managers and Twins representatives, representatives from the Minnesota Ballpark Authority and Hennepin County, and the architect/engineer. When the bidders through Mortenson were being interviewed and sitting in meetings, representatives from the Ballpark Authority and Hennepin County sat in to verify that Mortenson was being fair and that there was no favoritism.

### **Delivery Method(s)**

The prime contract with Mortenson was construction manager at risk. The project delivery was design-bid-build but fast-tracked with a GMP with contingencies. The design often was not complete when the contractors were bidding, so this contributed to the need for BVP. Contractors who would be able to operate on performance specs where the design was incomplete held a lot of value.

### **Risk**

It is greatly advantageous to reduce risk for everyone involved, including the CM, the owner, and the architect. The interview process is effective in eliminating bid errors, and the second chance to go back and adjust the bid before making it the final bid price reduces change orders. In other words, risk is worked out ahead of time, when it is more easily addressed, rather than mid-project, where it might adversely affect the cost and schedule. In one case, the lowest bidder during the interview went back, rebid his work, and that bid turned out to be the highest. It can be risky not to use best value on large customized projects like a ballpark. If a contractor who has never done a job like this before has the lowest responsible bid, its bid would normally be accepted, even if it does not appear to have the capacity. This can result in a contractor’s not being able to deliver halfway through the project.

## **Schedule**

Initially, the best value process slows down the schedule because it takes more time for each of the team members to go through the grading process and examine all of the criteria. The interview and rebid process took considerably more time than what a normal design-bid-build process would have taken when considering lowest responsible bidder. When selecting contractors, Mortenson felt that, in the long run, the familiarity the best value contractors had with the type of work saved the time of going through change orders.

In order to ensure the project would stay on an aggressive schedule, Mortenson was subcontracted on a separate “mini” GMP to self-perform the CMU and concrete work. An outside contractor could not have been expected to come in and perform to the schedule, and this would likely have slowed down the progress of the project. This was a case where Mortenson offered best value in the ability to perform within the critical path schedule. This arrangement also made it possible for Mortenson to work ahead of the design if it chose to do so. And if it did so, it then “owned” the CMU or concrete work. If changes showed up after the work was in place, Mortenson had to make corrections at its own expense.

## **Scope Management**

The public funding was managed by the Ballpark Authority. It was awarded \$350 million from the legislation for construction of infrastructure and the ballpark structure. The expectation was that all \$350 million would be spent. Any of the cost above original scope would be paid for by the Minnesota Twins, reducing the public’s exposure to additional cost.

The interview process before final bids are due adds to the management of scope because of the need to sit with the contractor and review the bid step by step to be sure agreement exists on the specifics of the work.

## **Time/Cost Relationship**

Time was critical because the opening date for the stadium, March 2010, was highly publicized. If the park were to open late, it would result in a lot of public pressure, loss of team revenue, and loss of ticket sales. It was important to get a contractor who understood the urgency of the project and who would be able to keep up with the aggressive schedule and its possible extra cost requirements, such as larger crews and overtime. Cost of the project always weighs heaviest when selecting a contract. After cost, the bid selection panel would look into who had the most to offer in terms of the rest of the criteria, including time.

## **Change Management**

Change management begins in the bidding process. During this process, estimators and project managers for the contractors were limited to a single contact, to ensure consistency of information for all bidders about what was being bid on. These questions and answers were available to all who were bidding on the work. This was done to assist in making the bids as accurate as possible and also to reduce major change orders if additional scope was discovered after bidding.

With fast-tracking and overlap of the schedule, bidders were often bidding on incomplete documents. In an attempt to control change orders on the project, they tried to hire contractors who they knew from previous experience would be more capable of “filling in the gaps” without generating large numbers of change orders.

Mortenson self-performed the CMU and concrete work on a mini GMP. If Mortenson as a CM wants to move ahead of design with the pace of the project, it is able to do so, but then “owns” the work. If changes show up after the work is in place, corrections have to be made at Mortenson’s expense. This is one of the only reasons Mortenson is as far along as it is. Biggest claims resulted from design issues with piling and steel and with contracts that had exposure to soils issues.

### **Separation of Responsible Parties**

The Twins and Ballpark Authority are the owners of the project. The Twins separately signed contracts with HOK/HGA, the architect and engineer, and the builder, Mortenson.

The parties responsible for the BVP grading process include the Ballpark Authority, Hennepin County, seasoned Mortenson PMs and Twins representatives, and the architect and engineer.

The Ballpark Authority was in charge of managing the interface between the infrastructure developments. The Twins were in charge of managing construction and design, which they got in exchange for signing the extended lease, paying \$120 million for the ballpark, and covering any cost overruns.

### **Conclusion**

It was agreed by those interviewed that BVP is successful. On jobs that need experienced contractors with the ability to maintain a challenging schedule and manage claims, best value is critical. Even though there was never a public bid for the CM (Mortenson), the Twins still feel they got a good price and the best value since Mortenson had been involved in so much of the pre-planning of this project.

The BVP grading process must be as transparent as possible. If a contract is “negotiated,” it should clearly document the reasons for all decisions made. These decisions must withstand public scrutiny.

Construction managers must get buy-in from all who are involved in the process. It is important that owners understand they are buying a process as opposed to a product.

One negative aspect of using best value procurement is that it can slow down the selection process. Extensive exploration of the bids and bidders takes a lot of time. The selection must start earlier in the project. When the time has been invested in selecting contracts based on best value, the construction process goes even more smoothly, with reduced risk.

Owners today expect projects to be delivered more quickly. With these expectations and the fact that design fees have been on the rise, there is less money to be spent on detailed coordination, making best value procurement a more important method of selecting contracts.

## Citations

Hunter, Ed. Personal Interview. 8 Oct. 2008.

Mehls, Dan. Personal Interview. 9 Oct. 2008.

Strassburg, Dick. Personal Interview. 9 Oct. 2008

Minnesota Ballpark Authority, 1 Oct. 2008, <http://www.ballpartauthority.com>

Major League Baseball, Minnesota Twins, 1 Oct. 2008, <http://minnesota.twins.mlb.com>

Ballpark Magic, Minnesota Twins Ballpark 2010, 1 Oct. 2008 <http://www.twinsballpark2010.com>

Photos From:

[http://minnesota.twins.mlb.com/min/ballpark/design\\_principles.jsp](http://minnesota.twins.mlb.com/min/ballpark/design_principles.jsp)

[http://www.ballparkauthority.com/index.asp?Type=B\\_BASIC&SEC={DCB023A1-5808-45F5-B18A-D8E8DA72C5A5}](http://www.ballparkauthority.com/index.asp?Type=B_BASIC&SEC={DCB023A1-5808-45F5-B18A-D8E8DA72C5A5})

<http://www.twinsballpark2010.com/baseball/minnesota-twins/stadium/Footprint.html>

[http://minnesota.twins.mlb.com/min/ballpark/metro\\_club.jsp](http://minnesota.twins.mlb.com/min/ballpark/metro_club.jsp)

[http://minnesota.twins.mlb.com/min/ballpark/sun\\_study.jsp](http://minnesota.twins.mlb.com/min/ballpark/sun_study.jsp)

Mr. Kris Hahn and Ms. Krystal Kurn, student team

## Introduction

This appendix details how South Washington County School District (SoWashCo) procures contracts for construction projects. SoWashCo School District currently has a new high school, East Ridge High School, under construction in Woodbury, Minnesota. It is also remodeling a few other schools within the district to incorporate technology wings and remove old mechanical work and install new. One school in the district that is undergoing a major remodel is Park High School in Cottage Grove, Minnesota. This appendix highlights East Ridge High School and addresses the Park High School projects because they are significant projects for the school district and were the general subjects of discussions with the school district.

In order to obtain funding for school construction projects, the school district must hold referendums for the school board. SoWashCo School District set up two bond referendums in November of 2006 for the residents of Washington County, Minnesota. The first bond referendum was for East Ridge High School, and the bond was issued at \$107 million. The second was for improvements and remodels for various schools throughout the district including Oltman Junior High School, Woodbury Junior High School, Woodbury High School, and Park High School. That bond referendum was issued at \$42 million.

## School District Project Delivery and Procurement

The owner, SoWashCo School District, typically uses a traditional design-bid-build delivery method. The school district selected and contracted architects Rego & Youngquist to design the new high school and the other remodels. A construction management firm, Kraus-Anderson, was hired as the owner's representative for construction on East Ridge High School and the other remodels. This type of contractual relationship is referred to as "construction management–advisory" (CM-A). The architect, CM-A, and the owner combine efforts and become the project management team. The school district holds all contracts with contractors on the project, a process commonly known as "multiple prime contracting." Once the construction documents are completed, the project management team issues an RFP (request for proposal).

In addition to the parties shown below, the architect may hold subcontracts with additional design consultants including structural, civil, mechanical, and electrical engineers, and possibly others. The construction manager may hold contracts with consultants such as a geotechnical engineer, surveyor, or environmental specialist.



When the bid process for East Ridge High School was complete, the school entered into contracts as shown below:

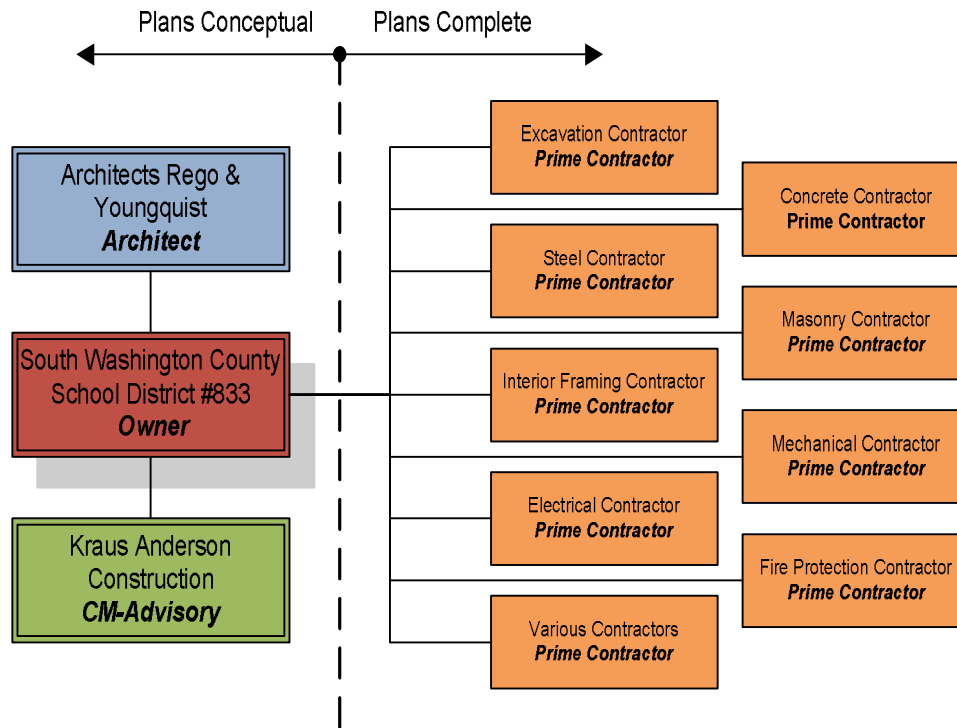

Figure 1. Organizational chart

To procure the architect and CM-A contracts, SoWashCo School District typically uses a request for proposal instead of low bid procurement since the district has a relatively good knowledge of construction. The school district has undergone construction since 1989. Under Minnesota Statute 16C.08, school districts and other public entities can use best value (selecting based on qualifications) rather than low bid to procure professional and technical services. Therefore, the school district short-lists construction management and design firms based on certain qualifications. For East Ridge High School and the remodel projects, the construction management and design firms were selected based on past experience with schools in the area. Construction management and design firms submit their proposals along with a written portion. A group of six or seven evaluators, of which two are board members, narrow the six firms submitting a bid down to two to be interviewed by the school district. During the interview, the firms are asked questions that detail qualifications, price, schedule, and a risk assessment. After the interviews, a firm is chosen and awarded the project. This is a type of best value system. In this situation there are no specific measurable requirements that the proposals are scored against. The selection is based completely on the discretion of the school board upon recommendation of the school district; however, it is a unanimous decision.

To procure the prime construction contracts, South Washington County School District, through the construction manager, will send out an invitation to bid the project to the public. The contractors will bid the work based on a complete set of construction documents and specifications for the project. The bids will be collected in sealed envelopes and are opened at

one time. The lowest responsive, responsible bidder is then chosen for each scope of work on the project. South Washington County School District feels it gets the best value possible by procuring the contractors based on low bid because the plans are complete and the risks likely to be very minimal.

### **Future Use of Best Value Procurement**

The use of best value procurement in a school district for construction contracts seems to be very rare, at least at this time. According to Bob Meeks of the Minnesota School Board Association, not many districts have used best value procurement for construction projects. The primary reason is that for a school district the most important criterion always appears to be price. Since price was the primary criterion used for the East Ridge High School and remodels, South Washington County School District felt adding the subjectivity was not necessary.

While discussing best value procurement with South Washington County School District, it was determined that a possible future use for best value procurement would be for construction contracts for extensive remodel projects. With remodeling projects, there are existing conditions that add additional risks to the project. By using a best value system similar to the University of Minnesota system, the school district could use best value procurement to assess the risks in the project and also select the most appropriate contractor to complete the project based on a pre-determined set of criteria that fit the conditions of the project. (For additional information on the best value system used by the University of Minnesota, please see the University of Minnesota appendix.)

Another opportunity for using best value procurement in a school district would present itself if a design-build delivery method is selected for construction projects. A design-build contractor could be selected based on proposals in a best value system. The contractor selected could also develop the initial budget used for bonding by giving the school district a GMP proposal. The GMP number would be the number voted on by the taxpayers of the county where the district is located.

### **Solicitation**

In order to get bidders for the CM-advisory and architectural contracts, SoWashCo School District invites selected short-listed firms to submit a proposal. The school district short-lists these firms based on their past experience; they look for firms that have performed similar work and within a radial geographic area from the site location. Firms selected are also short-listed based on owner's opinion of current projects. Construction manager and architect firms invited submit their proposals accompanied by a written portion.

Once the construction documents are complete, the construction manager gathers all the information for a certain bid package and invites firms to take part in the bidding process. Even though firms are invited during this process, bids are also put out "on the street," meaning they are public, and any firm may bid.

### **Qualification**

Based on their proposals and written portions alone, the few firms are narrowed down to three or four, who then come in to be interviewed by a group of six evaluators. The evaluation committee consists of school administrators, the principal, and school district employees. They evaluate the construction and architecture firms based on their similar experience, unique design, price, meeting budget on prior projects, change orders on previous projects, and visited

projects. The evaluators score the firms individually and provide a recommendation to the school board, which has the final decision. During the evaluation of bids, the construction manager and owner look at prices, receipt of addendums, and meeting of scope requirements. After the lowest responsive, responsible bidder is selected, it is notified and given the chance to revisit its bid to make sure nothing was missed, or else pull the bid (take it out of the running.)

### **Transparency and Neutrality**

This process is not blind and must result in a unanimous decision made by all evaluators. It is ultimately like a jury. Each person evaluates the companies during the interview process. All the evaluators sit together and discuss what they liked and disliked about all the companies. All parts of the evaluation, including price, schedule, quality, and past performance, are rated and ranked based on a set of weighted percentages. Once everyone is in agreement on the ratings, they are totaled and the winning contractor is determined.

All bids submitted by the contractors are sealed and publicly opened. The lowest responsive, responsible bidder is not given the opportunity to modify its bid, only to pull it. All low bidders are given this opportunity whether they are low by one dollar or one million dollars. If the lowest responsive, responsible bidder states it has met all criteria and doesn't need to pull its bid, the owner then proceeds into a contract with that firm, which begins work shortly after. In a lowest responsive, responsible bidder situation, it is difficult to prove a contractor is unqualified so long as it states it meets all scope requirements.

### **Delivery Method(s)**

SoWashCo School District enters into a contract with the architect and construction manager-advisory using a construction management delivery method. The architect and construction manager are brought in before the design is in place and both help the owner, who in a CM-A contract usually has more construction knowledge.

Once the architect and construction manager are on board, the conceptual designs progress further into schematic design and then into construction documents. The construction manager then receives all the bids and helps the owner determine which firm is the lowest responsive, responsible bidder. South Washington County School District uses the design-bid-build delivery method. Currently, only the top 25% of school districts in Minnesota can use the best value procurement method. South Washington County School District falls into this category but chooses to not use the method, due to the district's public nature. School District 833 depends on public funding and therefore feels it is necessary for bids to be publicly announced and opened.

### **Risk**

The main reason for bringing the construction manager and architect on at the same time is to reduce risk. The owner receives not only a design perspective but also a constructability review. Some other ideas of risk mitigation include holding reasonable expectations; having clear, complete, and accurate drawings; and being proactive. School District 833 actively executes these tactics throughout each project. SoWashCo School District consistently has projects under construction, whether remodel, renovation, or new construction, so it understands what has or has not worked in the past. Therefore, the district can apply what has been learned and apply it to future projects. Its expectations of contractors are fair: bendable but not breakable.

SoWashCo School District typically holds about 5% contingency on new construction projects. However, the construction manager-advisory, Kraus-Anderson, serves as the risk mediator on site for SoWashCo School District. Kraus-Anderson is on site daily overseeing construction and advising the prime contractors on what to do. However, if there are any issues that are not resolved for the prime contractors by Kraus-Anderson, the owner is still held responsible.

### **Schedule**

Changes cannot affect the schedule for any reason. Schools have a “drop-dead” occupancy date, which is the first day of school, and all contractors know this at the time of bidding. This is also one of the driving reasons that SoWashCo School District chose to use a construction management method. The district had had a bad experience in which the school was delivered 4.5 months late, which for schools is basically one year late. School districts, including SoWashCo, do not benefit from opening two months early because no one will occupy the building until the completion date. However, if the school cannot be delivered until after the completion date, it will not be able to open the doors until the next “first day of school.” The construction manager-advisory and the architect are made aware of the date before conceptual design is underway and therefore agree to this date before knowing much about the project. The school district chose to have multiple bid packages that included excavation before the structural, before the mechanical, before the finishes, before the landscape, before the furniture, so that the project could start as soon as possible yet still have enough time to plan out all types of work as needed on site.

### **Scope Management**

There was minimal scope definition when the construction manager and architect were brought on board. This helps the overall scope because all details should be thought out by the owner, architect, and construction manager. The only known parts of the project at the time these two entities were brought on were the location, overall purpose, and occupancy of the building.

The scope of the project and its relationship to the schedule are mitigated through bid package separation. The order of bid packages is determined by schedule order (i.e. excavation occurs before foundation, which occurs before the structure, and so on). These packages must be well-defined before being sent out for bid in the design-bid-build method.

### **Time/Cost Relationship**

By issuing bid packages separately, the owner and its agencies are providing themselves with more time to validate the scope set forth in each package. They are not in a rush to send out multiple scopes in one attempt. Another check done on the scope of the work is verifying with the lowest responsive, responsible bidder that it has met the scope set forth in the request for proposal. Also by having the construction management and architecture firms work together to determine design and constructability, any delays in determining which is more imperative are reduced.

### **Change Management**

Most change orders seem to stem from an owner error or unforeseen condition. It is through careful consideration of the future tenant that the architect feels risks can be mitigated. In other words, sitting down with the tenant (also known as teacher or administrator), determining how the space should be laid out, down to which way the cupboards should open, leaves less room for the owner to change its mind midway through the project construction. Being proactive is

one of the most common tactics. Addressing the issues before they become issues—not only bringing them up, but also arriving at a solution with those affected—minimizes, if not eliminates, the risk. For example, the flooring in a bathroom was changed from vinyl to tile. By addressing this issue with the flooring contractor before floor work or even ordering is begun will prevent loss of time and allow determination of a tile comparable to the vinyl in cost, function, and appearance.

### **Separation of Parties**

All parties were in agreement that this contractual and team effort worked very well for them. SoWashCo School District has ample opportunity to observe and implement the norms of construction. This may be the obvious reason why it holds almost all contracts: it knows what to expect. SoWashCo holds individual contracts with the construction manager-advisory, the architect, and the prime contractors. Therefore, the only link between contractors is their contract with the owner. If one prime contractor is not satisfied with another prime contractor, it must go after the owner because of the lack of contract between parties. This can be detrimental for an owner that is unaware of the general, legal, and accepted sides of construction. The owner is knowledgeable enough to know what is acceptable and what is not, so it feels it is treated fairly and that the CM-advisory and architect have its best interests in mind. The architect works with the CM-A to complete the drawings.

As for the prime contractors, there are pros and cons to this type of contracting. For one, the supervision of the entire project is done by the CM-A firm, which does not hold a contract with any of the firms employed. The lack of contract makes all issues go through the owner.

### **Conclusion**

Those contributing to the East Ridge school project feel as though certain issues could have been mitigated more easily if best value had been used instead of low bid. On the other hand, SoWashCo School District feels it received the best value from most of the contractors. So if an owner feels the low bid contractor would have also been the best value contractor, what is the point in introducing more risk by having a best value procurement process, which involves more subjectivity? However, best value was used in obtaining construction management and architecture services, as permitted by law. Best value procurement allowed SoWashCo School District to be more subjective and make its selections based on the designs and services it felt suited its needs best. Best value also allowed it to pick services of companies that had previous similar experience and were in a certain geographical area. Overall for the purpose of completing this project within budget (which is extremely important), the project management team is highly experienced in keeping these projects under control and getting a finished project that will suit the final user's needs.

### **Citations**

Mike Vogel, Assistant Superintendent for Operations, South Washington County School District, [mvogel@sowashco.k12.mn.us](mailto:mvogel@sowashco.k12.mn.us)

John Huenink, Vice President, Kraus-Anderson Construction Company, [john.huenink@k-a-c.com](mailto:john.huenink@k-a-c.com)

Paul Youngquist, Architect, Architects Rego & Youngquist, [pyoungquist@aryarch.com](mailto:pyoungquist@aryarch.com)

Bob Meeks, Executive Director, Minnesota School Boards Assn.

Mr. Marc Staufiger and Mr. David Meyers, student team

## **Introduction**

The views and conclusions formulated on the topic of best value procurement were obtained through interviews with private sector construction project owner's representatives. The owner's representatives interviewed for this study have extensive experience in procuring and managing both commercial and residential construction projects. The interviewed professionals were also informed of the definition for best value procurement statutes in Minnesota 16C.02, passed in 2007.

## **Private Sector Defined**

This appendix will refer to a specific group of construction project owners as the "private sector." Construction project owners in the private sector generally obtain project funding from internal sources, including investments, donations, and revenue, rather than obtaining public funding through taxes. Private sector owners are not required to use a specified method to procure construction services. For example, private sector construction project owners are not required to publicly seek bids for construction services by a government authority. Choosing the selection methods for obtaining construction services is left to the discretion of the construction project owners and their respective representatives.

## **Organizations Interviewed**

*Sterns and Associates, LLC*

*Ms. Teresa Sterns*

*President and founder*

Sterns and Associates, LLC has been representing private sector construction project owners since its formation in 1999. To date, Sterns and Associates, LLC has successfully managed over 45 construction projects, translating to hundreds of millions of dollars. Sterns and Associates, LLC provides construction services including project development, project management, and support. Most of the company's projects have been in Minnesota.

*Wellington Management*

*Mr. David Bergstrom, CPM, FMA, RPA*

*Director of Project Management & Construction Services*

Since its foundation in 1985, Wellington Management, Inc. has constructed and owned 88 commercial properties, amounting to over \$375 million. All of these properties are within the Minneapolis and Saint Paul metro area. Wellington Management, Inc. staff includes project managers, property managers, accountants, and engineers.

## Use of Best Value Procurement Within the Private Sector

The best value method of procurement for construction services, as written in Minnesota Statute 16C.02, is not used within the private sector. However, this does not mean that construction project owners in the private sector do not use methods of construction services procurement that are similar to the best value procurement method.

Construction project owners in the private sector have the freedom and ability to choose any method of construction services procurement they like that is defined as the best value by their own standards because they generally do not have public financing for their projects.

Private sector construction project owners have taken full advantage of their lack of regulation concerning construction services procurement. Because they are not specifically required to publicly hard bid their construction projects, private sector owners have formulated new and alternate methods for procurement of construction services other than the traditional lowest responsive, responsible bidder method. Alternative methods have been specifically designed for, or by, individual construction project owners, or even for an individual project. This does not mean that the traditional procurement methods are not used in private industry. However, if traditional methods are used, usually no limitations or obligations are placed on the owner to select an entity solely on scoring. The owner will normally retain the ability to have final say in selection.

Today, the commonly used methods for construction services procurement in private industry are design-build, negotiated, low bid, guaranteed maximum price, or other hybrid methods. The owner will normally choose the procurement method that will most likely achieve its self-described best value on its construction project. Each construction project owner in the private sector will usually have its own definition of best value. This is a key element that separates public sector best value procurement from private sector best value procurement. The public sector method of best value procurement has a set definition; the private sector method of best value procurement can be redefined owner to owner and project to project.

Though private sector construction project owners have been using their own form of best value procurement for many years, they would likely never use the best value method of procurement for construction services as written in Minnesota Statute 16C.02 because it would negate the advantages of being a private sector construction project owner. Owners using best value procurement method as described by statute would essentially be giving up their decision-making power.

Essentially, then, there is no reason for a private sector project owner to follow the rules of the best value method of procurement as defined by Minnesota statute. A private sector owner could use a method that encompasses all the elements of best value procurement such as scoring, qualification, and selection criteria, while not giving up its right to have the final say in selection. By not following the best value procurement method as defined by statute, a private construction project owner could avoid any obligation to award to a specific contractor, no matter what the outcome.

In order to choose their procurement method, private sector construction project owners will outline the critical aspects, wants, and needs of their particular projects. The method of procurement for each project, like its objectives, may vary.

Regardless of the procurement method, most construction project owners in the private sector will choose to qualify multiple bidders as well as meet with them prior to selection. Obtaining bids from multiple contractors, though not required, will keep prices competitive.

A key consideration in the private sector of construction is the fact that owners are not required to be neutral or fair in their selection processes. They are not required to publicly and objectively bid out their construction projects. Private sector owners have the advantage of making the final decision in selection process, regardless of scoring or price outcome. This means that private sector owners, if they so choose, can select any contractor without reason or recourse. Though this is not likely to happen, they still have the ability.

Private sector construction project owners are not required to use any specific methods of procurement, so it is not likely that any will ever use the best value procurement method as defined by Minnesota Statute 16C.02. because they have the freedom to tailor a procurement method to their exact project needs. Since no project is exactly the same, it is beneficial to any construction project owner to have the ability to customize its procurement method to fit the specific project needs and objectives. Procurement methods used by private sector owners can be customized to have a higher or lower influence on project aspects such as cost, schedule, quality, risk, design, or anything else. By doing this, private sector owners will essentially be defining their own form of best value procurement.

### **Specific Practices of the Private Sector**

- **Solicitation and Qualification**

When soliciting contractors to bid on a private sector construction project, owners will often extend requests to a predetermined group of contractors and subcontractors. This predetermined group is often composed of organizations that have collaborated with the construction project owner in the past and have succeeded in delivering a quality project. If the private sector construction project owner has not worked with a specific contractor or subcontractor before, it will often look to that contractor's reputation or request qualifications within the industry to formulate the contractor's bias prior to selection. Project owners will also have the contractor prove its ability to carry out the work. This may require the contractor to show experience in working on similar projects, bonding capacity, current availability, safety record, and sufficient working capital.

- **Transparency and Neutrality**

Regardless of the procurement method used, private sector construction projects will not always have completely neutral and transparent methods of contractor selection. In most cases private sector owners feel that it is to their advantage to know who their bidders are. Often bias is evident in the selection of a contractor, designer, or subcontractor. The owner's bias is often based on past professional experience with the proposing party. Depending on the case, the biases of the owner may or may not outweigh the scoring criteria that have been established by its self-defined best value procurement method.



- **Delivery Methods**

Private sector owners have the freedom to choose whatever procurement method will best suit their project's needs and objectives. Since the majority of construction projects are unique, a private sector owner will attempt to use a delivery method that is suited for the needs and qualifications of the project. For example, on a complex or first-time project, a private sector owner might choose to use a delivery method such as negotiated bid because there is a higher potential for unforeseen errors. However, when a project has been built many times before, an owner might opt to use a hard bid method of procurement because it already has the design and process down to a science.

Selection of a delivery method in the private sector of construction will depend greatly on the specifics of a project as well as the project owner's preferences and objectives.

- **Risk**

By tailoring their procurement methods to meet their specific project needs, private sector construction project owners will greatly reduce their project risk. Most private sector owners will conduct interviews with potential contractors to try to identify the areas of risk within their projects. By identifying areas of risk in the project before notice to proceed, owners, contractors, designers, and engineers alike will be better prepared to carry out their project tasks correctly and efficiently. Private sector owners have also reduced their risk by soliciting only to qualified contractors and defining project objective criteria within their procurement method.

- **Schedule**

Compared to the lowest responsible bid procurement method, an increased amount of time can be spent at the beginning of a project to design a custom procurement method. The additional time spent at the beginning is thought to be made up during the project because there are fewer unforeseen issues. This can be especially true on very complex projects.

Private sector owners believe that by designing a procurement method to be their own best value, they will have improved control of the project schedule. This can be attributed to the qualification of contractors, increased preconstruction planning, and early risk identification.

- **Scope Management**

By being able to define their own best value for a project, private sector owners will have an increased amount of control on their project's scope. For example, if an owner's project scope values quality over schedule and cost, the owner can use that information to qualify only contractors who have a reputation for a very high quality of work. Having the ability to hand-select the entities involved on the project is to the owner's advantage.

Interviewing potential contractors prior to selection also helps private sector owners manage their project's scope. The interviews may aid in confirming compliance with materials, specifications, and needs laid out by the owner. This is especially important when the project is delivered in a design-build method.

- **Time and Cost Relationship**

Contractor qualification and interviews play a role in time and cost relationship for private sector construction projects. Private sector owners address time and cost relationship issues in their interviews with construction bidder prior to selection. Contractors that have come in above cost and late on previous projects will likely not be considered in the selection process. Often changes can be negotiated between the contractor and the owner rather than relying on change orders.

- **Change Management**

By interviewing bidding contractors during the selection phase of the procurement process, owners and contractors can work out any potential changes before the project breaks ground. Changes that may have occurred due to lack of planning or oversight can be addressed and planned for so they do not disrupt the project during construction. Contractors will often negotiate changes or absorb them in order to save face with the owner.

- **Separation of Responsible Parties**

The responsible parties involved in a construction project in the private sector can often vary. In some cases a private sector owner will hire an entity knowledgeable in construction to act as its representative. The design entity will often act as the owner's representative, though it can also be a third party. If the owner has enough experience it may choose to represent itself.

On the building side, some of the self-defined best value procurement methods will require a design-build team including a contractor and design team as one entity. Other procurement methods will split the contractor and design team into two separate entities. The project objectives, scope, and design will play a role in deciding how to organize and define responsible parties.

## **Conclusion**

Owners in the private sector of construction will not likely ever use the best value procurement method as defined by Minnesota statute. Many private sector owners have been using procurement methods similar to best value for many years; however, there is a key difference between the public and private versions of best value procurement. Public projects are required to use a lowest responsive, responsible bidder method, or if allowable, the new best value procurement method. Because owners in the private sector are not limited to these two methods, it is to their advantage to design their own best value procurement methods to fit their project and personal needs.

## **Sources:**

Minnesota State Procurement .Chapter 16C, all sections. 2007  
Mr. David Bergstrom. Personal interview. October 16, 2008  
Ms. Teresa Sterns. Personal interview. November 19, 2008

Mr. Mark Drewiske, student team

### Introduction

Training for best value procurement (BVP) and the definition of adequate training are extremely gray areas. Due to the relative newness of the delivery method of BVP and the unavailability of training, many entities are apprehensive about undertaking a project in which this method is used. Only a few groups have the resources to put together an adequate seminar on the subject and offer a certificate of attendance.

Perhaps the only recognized training program in the country for BVP is the Performance Based Studies Research Group (PBSRG) at Arizona State University (ASU).

### Laws

The Minnesota Department of Administration has the ability to distinguish who may be deemed “certified” to use BVP. The main reason this ability has fallen to the Department is the lack of certified training programs available in the area.

### City of Roseville - Interview with Jeff Evenson

How did you learn about the BVP delivery method?

Roseville is the first city in the state of Minnesota to use BVP. Outside of the immediate staff in the Park and Recreation Department, there wasn't really any influence into deciding to pursue this type of delivery method. This method was used in the city of Peroia, Arizona, and its city office was contacted to see how the method was used and to discuss the nature of the program and its effectiveness.

How did you come to select ASU for your training?

Only knew of ASU and the University, and since the University doesn't have its own training program, the obvious choice was to go with ASU and PBSRG. Attended a seminar put on by the League of Minnesota Cities (LOMC), but it was purely informational, and the LOMC has not put on one since. It sent a few of its members down to a conference at ASU and decided that this training program was the best fit for its venture.

What sort of issues, if any, did you encounter during the training period?

Could not think of any.

Other key points:

- A price was negotiated that would include both training and assistance from ASU in implementing the project.
- Felt that the exam was nonsensical, pure multiple choice. ASU sent out excerpts of the text to use as a study aid a week or so ahead of the exam and participants felt like they had to cram for the exam. This was quite an undertaking for them because they didn't

have much experience lately with the idea of studying and taking an exam in an educational format.

- Believed that there were statistics about the previous test results. These passing rates are approximate and Evenson couldn't recall if they are exact or not.
  - 1st year: 3/100 or 3% of attendees passed.
  - 2nd year: 30 % passed.
  - A 70% or higher is required to be certified.
- Participants received a certificate of completion. However, a restructuring of the program took place after they were certified. The five levels of this restructuring are described below. Evenson said he would be interested to find out what level their certification would be under the new system.
- Further training is not planned. Participants feel they have enough competence to complete a future project using this method, but they will definitely use ASU as a resource to help plan and assist with their scoring procedures.
- Evenson has spoken with John Savicki. They discussed at length the basics of the project, and Evenson helped develop Savicki's project team. (Evenson, 2008)

### ***Arizona State University***

ASU's PBSRG offers one of the nation's only training programs with recognized merit. PBSRG's Web site describes the content and expected results of its highly structured, five-level certification program. However, this program has large drawbacks. It is quite costly, and it is the only program of its type in the United States. Therefore, entities without sufficient financial resources will have to search for an acceptable alternative in order to comply with the Minnesota statute on BVP delivery.

### **Training & Certification Programs** (Copied from PBSRG website)

#### Level I:

General Education of Best-Value Concepts Level I provides a general overview of Best Value Procurement and Information Measurement Theory (IMT) concepts. The educational session is used to provide a brief (2 hour) introduction to best value concepts behind the Performance Information Procurement System (PIPS). Level I serves to provide a general education and does not train (nor is intended to train) individuals on the best-value process. This education is intended to inform individuals of the efficiency and success of IMT and PIPS. With this information, potential users can decide whether they want training in IMT/PIPS. The cost of Level I Education is \$1,500 for group education, plus travel expenses.

#### Level II:

Certified Training Level II Certification covers the fundamental best-value concepts associated with Information Measurement Theory (IMT) and the Performance Information Procurement System (PIPS). This 14 week class is split between in-class presentations and on-line video presentations over the Internet. In-class presentations have been held on the University of Minnesota Campus (Minneapolis), or a nearby facility. The class includes a textbook, quizzes, exams, and homework assignments. Students must receive a "pass" grade to receive a "Certification of Training on Best Value Procurement". Individuals that pass the certification are

expected to be capable of implementing the PIPS Best-Value process with minimal (to none) assistance from the PBSRG. The cost of the 14-Week Certification Class is \$5,000 per student.

### Level III:

Pilot Project Education & Support Level III provides users with education on implementing the PIPS Best-Value process on one pilot project. The education and support includes:

- Preparing all best-value project documentation (including the RFP or RFQ)
- Preparing a project procurement schedule built around best-value activities
- Educating vendors on the best-value process
- Analyzing vendor past performance information (up to 1,000 surveys)
- Analyzing bid proposals
- Identifying the potential best-value vendor
- Weekly Reporting System (documenting unforeseen risks on a weekly basis)

Level III education is intended to provide education services only on a one-time basis. Users that choose to continue their best-value efforts must pass the certification exam outline in Level II (Level III Education/Support includes the Level II Education). The cost of Level III Education/Support is approx. \$15,000-\$35,000 (depending on the scope of the pilot project).

### Level IV:

Complete Program Implementation and Certification Level IV offers a complete education and training package. This package is tailored to each user's requirements, but generally includes education and training on implementing the PIPS Best-Value selection process on four projects. This includes the education and training functions outlined in Levels I, II, and III. This level of education/training is very similar to the University of Minnesota's efforts to improve the efficiency and performance of their organization. After completing Level IV, the individuals who have been trained are also eligible for Level V Certification, which permits the individual to train other potential users of Best Value. Level IV also provides the user with five (5) seats to the Annual Best Value Conference at ASU. Users will establish a long-term strategic plan on how to sustain the program after education and training are complete. Users are expected to be able to maintain the PIPS Best-Value process with minimal (to none) assistance from the PBSRG at the conclusion of the pilot projects (bearing in mind that they must pass a certification exam). Level IV can also be utilized by a group of users who act as one user. This group must meet at a central location for all meetings, and each individual user must pass the certification exam to continue their best-value efforts. The cost of the Complete Program Implementation is approximately \$75,000-\$115,000 (depending on the scope of work).

### Level V:

Instructor Certification Level V is reserved for individuals who want to be certified as independent trainers/educators. This certification will allow individuals to train other groups/individuals on the PIPS Best-Value selection process. Level V certification requires:

- Level II certification. This can be accomplished by taking the class outlined in the Level II program, or by attending the annual Best Value conference at ASU. Either option requires that the individual pass the certification exam.

- Implementing the PIPS Best-Value process on a minimum of four (4) projects (one with assistance from the PBSRG, and three projects with the correct/complete documentation).
- Compile, maintain, and provide all documentation on the PIPS Best Value tests to the PBSRG for verification.

Due to continuous improvements in the best-value process, Level V Certification requires certification renewals on a yearly basis. This is achieved by attending the annual Best Value Conference at ASU, and passing the yearly certification exam. The cost of the Instructor Certification is approximately \$1,500 annually.

**Detailed Education and Research Capabilities:** (Copied from PBSRG website) (PBSRG.1, 2008)

PBSRG conducts the following activities related to education and research:

1. Educate and collaborate with core personnel of a research client to create a strategic plan for the testing, analysis, and implementation of best value and leadership based concepts and processes within an existing organization or environment. This could include:
  - Assistance in the development of a strategic plan, both at the project level and organizational/department level. The strategic plan will entail goals, constraints, opportunities, and risks, with action and mitigation plans for each.
  - Identification of potential test and education opportunities within the client organization.
  - Education, testing, and process analysis schedule.
  - Identification of measurements to quantify change and value brought by using best value and leadership concepts (or lack of change/value). This will indicate if best value initiatives within the client group are and can be successful. The value measurement can be done on process and managerial structure applications as well as on projects.
2. Identify, educate, and train area leaders, project managers, supervisors, heads of facilities and any other key personnel or organization areas that may benefit from best value and leadership principles and processes.
3. When test scenarios are identified, the best value and leadership research can be applied in the following scenarios:
  - **Project and Services Level:** the best value process can be applied to the selection, contracting, and measurement/monitoring of procured services. This includes:
    - Finite project situations (such as construction, purchasing (e.g. software or equipment) or short term service/consulting). The best value process can be overlaid onto any existing delivery method.
    - Long term service agreements (such as service contract for janitorial, dining programs, security, etc.)
    - Each of these situations will receive the following (including transfer of all PBSRG pertinent forms, documents, and information to the client organization):

- § Development of an RFP for the selection, working within the constraints and requirements of the client. Includes schedules, scope, etc.
  - § Education and testing of a best value selection process.
  - § Education of vendors
  - § Collection of vendor past performance information
  - § Risk assessment and value added plan evaluation
  - § Interview of key personnel
  - § Decision-making model development, execution, and analysis
  - § Education of pre-planning and quality control
  - § Owner assistance in contracting the vendor
  - § Development and Implementation of project and performance tracking tool
- **Measurement and Existing Process Improvement:** the best value process incorporates leadership principles that use measurement and accountability systems to instill a culture of risk identification and minimization, along with performance and continuous improvement.
  - The PBSRG can implement and track a simplistic information process that will motivate vendors and personnel to exhibit leadership traits. This can be applied to an existing process (such as estimating regimes and LEED) to measure value, performance, and identify potential areas of improvement.
  - Baseline performance will be established and any changes/deviations due to process enhancement will be measured and benchmarked.
  - The same information process can be used externally and internally.
- **Organizational Transformation:** the fundamental concepts and principles that have led to the high levels of success in the application of the best value process are the same upon which an organization, company, or group can transition itself into a more efficient and productive entity. The movement to a “Best Value – Leadership” based organization requires vision, the ability to change, and a process that allows the transformation to effectively occur. The research process can help an organization:
  - Identify if they are capable to transforming into a best value leadership based group
  - Set a strategic plan to make the transition
  - Identify risk and encumbrances to change – allowing them to be minimized or avoided.
  - The move to efficiency and measurement will cause resistant. A plan must be in place to manage any corporate “pushback.” The greatest aid to sustaining an efficiency model is proper data collection that can show:
    - § The value added by the change
    - § The gains in efficiency and the reduction in work caused by the change
    - § The path forward and what benefits it will bring.
  - The transfer of education and knowledge allowing an organization to implement any best value and/or leadership based philosophy without the aid of ASU. The people within the client organization will become experts and this knowledge transfer will filter down through the group and into all vendors, suppliers, consultants, etc. It is a new enterprise model.

4. Research and documentation of all initiatives undertaken by PBSRG at the client organization will result in:
  - Detailed case study and implementation history, allowing transfer of knowledge, lessons learned, and step-by-step procedures used by other client sectors and groups.
  - Measurement of change and value from before best value application through best value application.
  - Catalog of “how to” manuals and case studies for application of various best value methodologies to specific project or service situations, including any process evaluations and enhancements.

### **Other Educational Entities As Training Providers**

The League of Minnesota Cities held a seminar which briefly covered the BVP process. It did not offer training, but was informational and explained what BVP can offer. One unnamed source who attended this seminar said the meeting was “nearly pointless beyond the extent of a meet and greet.”

Entities are reluctant to undertake training, for the following reasons:

- Cost: The program is very expensive if pursued with ASU and PBSRG.
- There is resistance in the construction field.
- BVP is relatively new and understanding of its failures and advantages is not yet developed. Apprehension exists toward pursuing this method and acquiring training.

### **Sources:**

Evenson, J. M. (2008, November 12), park project coordinator. (M. Drewiske, interviewer)

PBSRG.1, (2008), PBSRG, *Performance Based Studies Research Group, Overview*.

Retrieved 10/27/2008 from PBSRG, Performance Based Studies Research Group:  
<http://www.pbsrg.com/overview>

PBSRG.2. (n.d.), PBSRG, *Performance Based Studies Research Group, Education*.

Retrieved 10/27/2008 from PBSRG, Performance Based Studies Research Group:  
<http://www.pbsrg.com/education/training-certification>